

User Manual

Software DSP Machinery Control

Version: 4.3.1

DSP Machinery Control

Copyright and Trademarks	7
Introduction	8
Program launch	8
Configuration scheme	9
Main Screen	10
1) Configuration Tree	10
2) Item detail	10
3) Working window	10
Tabs	11
Results	11
Portable Equipments	11
PC connection to upload and download Routes	11
Upload Routes to equipment	12
Download Equipment Routes	14
Equipment disconnection	16
Loading a Route to a file	16
Database Copy	17
Visualizations	17
Visualization modes	19
Trend	19
Use of Mouse	22
Bar and Clocks	23
Clock format without alarms	23
Clock format with alarms	23
Point Trend	24
Comments	24
Routes	26
Creating and editing Routes	26

Report	29
PC connection to download Report	29
Download Equipment Reports	30
Analysis of Spectrums, Waveforms and/or Orbital Graph	32
Chart Comparison	32
System Menu	33
Administration	33
Connect to another database	33
Plant creation	33
View	34
Sensors	34
Alarm Masks	36
Mask Creation	36
Bearings	38
Users	39
Languages	39
Main tree update	39
Tools	39
Configuration	39
Directory Selection	40
Periodic export	40
E-mail account	41
Status alert	41
Start status monitoring by email	41
Create Report	41
Configure analysis tool	41
System units	42
Delete duplicate measurements	42
Servers	42
Tree configuration	42
Plant	43
Subplant	44
Equipment	44
Copying Equipment, Points and Measurements	47
Copy or Move an equipment to another Database	49

Point	50
Measurements	55
Measurement setup window	55
Variable	57
Channel	57
Maximum frequency (Hz)	57
Measurement Type	57
Lines/Samples	57
Averages	57
Window	58
Gain	58
Filter	58
1- 1.250 Hz a 2.500 Hz -3db filter	59
2- 2.500 Hz a 5.000 Hz -3db filter	60
3- 5.000 Hz a 10.000 Hz -3db filter	60
4- 10.000 Hz a 15.000 Hz -3db filter	61
5- 15.000 Hz a 20.000 Hz -3db filter	61
Unit system	61
Range	62
AC auxiliary channels	62
DC auxiliary channels	64
Include an Off-Route measurement to the tree	65
Access to history	66
Results list	67
CSV Export	70
Results graphs	70
Mouse right-click options	76
Edit / Delete Plant or Subplant or Equipment or Point or Measurement	76
Add Subplant or Equipment or Point or Measurement	76
Group Subplant	76
Start data export	76
Edit export	76
Enable multiple export	77
Replace Measurements	77
Include teams in Report	77
Scenes	77
Sort Points	78
RPM change	78
Copy	78

Add to orbital chart	79
Add spectral mask	79
Data export	79
Move measurements	79
Delete Measurements	80
Analysis tools	80
Cursor Marking Main Icon	81
Harmonics	81
Side bands	82
Picos Máximos	82
Main icon for changing scales in spectrum	83
Hz/CPM - Change of units in frequencies:	83
Metric/Imperial - Change of measurement system in spectra:	83
Velocity Measurements	83
Linear / Logarithmic - Amplitude scale change in spectra:	83
G / m/s2 Change of measurement system in spectra	85
Configuration tools	85
Vertical axis zoom	85
Maximize spectrum	85
Spectrum reset	86
Calculation of actual RPM frequency	86
Save a spectrum	86
Images, texts and data	87
Copy image to clipboard	87
Send spectrum by e-mail	87
Print spectrum	87
Export Spectrum to Microsoft Word	88
Skype	88
Play	88
Spectral distance	88
Spectrum by order	89
Bearing failure frequencies	89

Gear and Belt Frequency	89
Diagnostic tools in velocity and displacement.	90
Balancing analysis	90
Alignment analysis	90
Mechanical clearance analysis	90
Velocity diagnostic tools.	91
Component identification	91
Diagnostic tools in acceleration	91
Bearing analysis	91
Lubrication analysis	92
Math conversion	92
Maximize graph	93
ISO – IEC norm	93
Alarm level modification	94
Electrical analysis	95
Waveform analysis tools	95
Orbital chart	95
Reports	96
Route reports	97

Copyright and Trademarks

October 2021

Copyright © 2012-2033 SEMAPI CORP

All rights reserved. No part of this publication may be reproduced, stored in a retrieval system, or transmitted, in any form or by any means, electronic, mechanical, photocopying, recording, or otherwise, without the prior written permission of SEMAPI.

Information contained in this publication is provided for informational purposes only and is subject to change without notice. SEMAPI and its associates do not assume any responsibility for damages or losses that may arise from use of information contained in this publication. Software described in this book is furnished under applicable license and registered under Patent Number Pending in the US and foreign counterparts.

This manual is distributed with Hardware and Software which includes an end user license agreement, this manual, as well as software described in it, is furnished under license and may only be used or copied in accordance with terms and conditions of said license.

Except as provided in the license, any part of this manual may not be reproduced, stored in data retrieval systems, or transmitted, in any form or by any means, electronic, mechanical, recording, or otherwise. other, without prior written authorization of SEMAPI. Please note that content of this manual is protected by copyright laws even if it is not distributed with software that includes an end user license agreement.

Content of this manual is provided for informational purposes only, and is subject to modifications without

prior notice, without this being construed as a commitment by SEMAPI, which does not assume any obligation or responsibility for errors or inaccuracies that may be contained in the informative content of this manual.

Remember that existing illustrations or images that you want to include in your project may be protected by copyright laws. Unauthorized incorporation of such material into your new work may be subject to violation of the intellectual property rights of the copyright holder. Be sure to obtain proper permissions from the copyright holder.

Introduction

Phrases DSP Machinery Control®, DSP Remote Monitor®, DSP Compact WRM, DSP Full Condition®, DSP Logger Expert® are registered trademarks of SEMAPI.

SEMAPI logo is a registered trademark. All other trademarks are property of their respective owners.

DSP Machinery Control software allows you to manage measurements transmitted by hardware connected to system, regardless of the family of machine it controls. All hardware associated and connected to network will be managed by software.

Creation of database and subsequent analysis of measurements will be task of software system.

Program launch

DSP Machinery Control software will be installed generating its own folder in program launch section.

To start it, look for the icon under DSP Machinery Control.



Once executed, login screen is displayed.

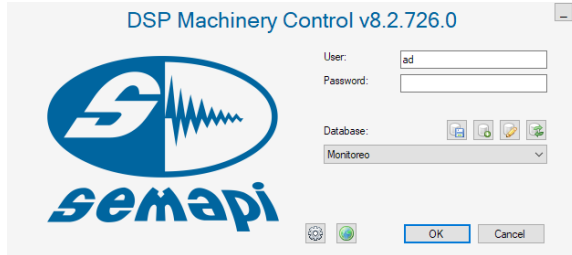

The first time it is executed, database on which it will work must be created. To do this, click on the icon



which will allow to create a base

Enter a name and click on the green check mark.

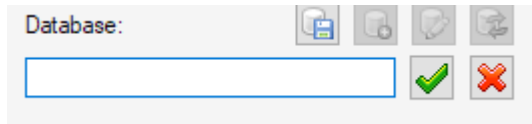

Software will generate corresponding base and stays on this screen to select the base with which you want to work (remember that you can generate the number of bases that user wants – each one is independent of the others)

Configuration scheme

For necessary configurations, we use tree schema.

It begins with Plant, which can be subdivided into Subplant. Keep in mind that inspection routes are generated at this level, so that in each Sub-plant there should be equipment that belongs to same measurement route.

Next level is **Equipment**, which contains **Measurement Points**.

Finally, each **Measurement Point** can have 1 or more **Measurements** according to what is considered necessary.

Main Screen

Upon entering the program, main screen is presented, which is divided into 3 sections.

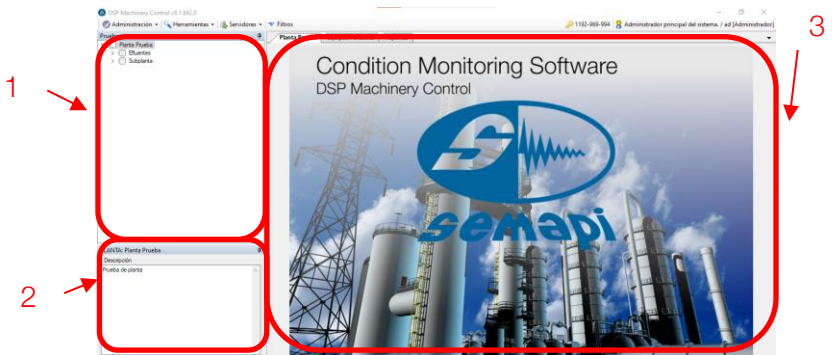

1) Configuration Tree

In this section all the equipment, points, measurements, etc. that correspond to plant are configured and grouped.

2) Item detail

Displays a summary of selected item settings.

3) Working window

Depending on where the cursor is positioned in window 1) different tabs will be shown to be able to work. One that will be permanently enabled in all selections is "Portable Equipment"

a) With Plant selection, "Reports" Tab is added

b) With Subplant: "Reports" and "Routes"

- c) In Equipment's: "Reports", "Routes" and "Visualizations"
- d) At Point level: "Routes" and "Displays"
- e) Finally, in Measurement: "Routes", "Displays", "Graphs Comparison" and "Results".

Tabs

Results

This tab, which is present only at "Measurements" level, is explained in Analysis Tools section.

Portable Equipment's

In this tab, DSP Machinery Control software allows you to interact with portable equipment.

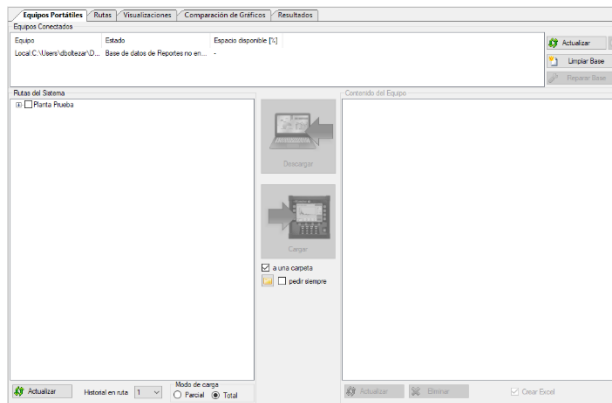

PC connection to upload and download Routes

To carry out this process, it is necessary to enter to module *Data Collector*:



Activate connection function with icon

Hardware will wait for USB cable to be plugged into a port on a PC.

Important: If USB cable is connected before enabling this function, hardware connection may not be accessed with software.



Upload Routes to equipment

Equipment must be accessed in "Connected Equipment" area to be able to load routes.

Note: to update connected equipment (by reading its database), you must click Update.

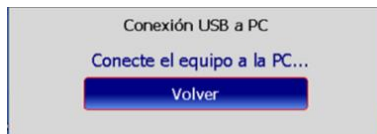
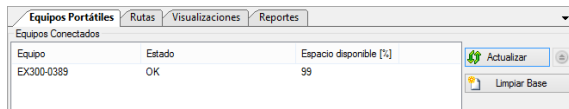

If you want to clean computer's database, click on Clean Database.

Once connected Hardware is selected, check the route that you want to transfer from software to equipment (Box where it says: System routes).

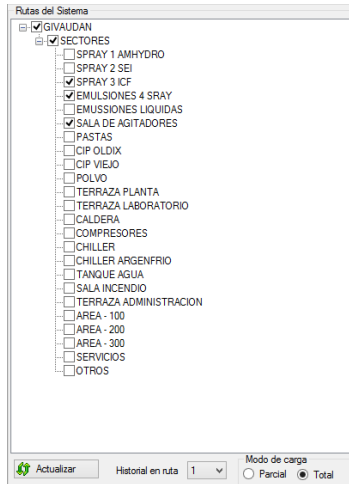

In the event that you want to select or deselect all routes, you must check or uncheck (respectively) plant.

There are two modes available to upload routes to equipment:

Partial: loads selected routes, without deleting those that were already on device. Your process is just copying.

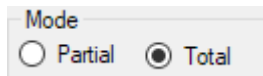

Total: loads selected routes, replacing and deleting those loaded in advance on equipment.

Note 1: charging time in partial mode is 3 times greater than in Total mode.

Note 2: Routes can be updated (if new ones have been made) by clicking Update icon.

Once routes you want to transfer from software to equipment have been defined, you must click on Load icon.



Then wait for selected routes to be saved on device.

Download Equipment Routes

Device must be accessed in "Connected Devices" area to be able to download routes contained in it.

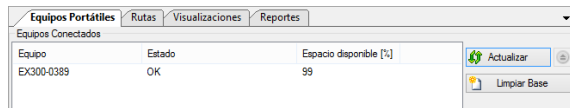

Note: to update connected equipment (by reading its database), you must click Update.

If you want to clean computer's database, click on Clean Database.

Once connected Hardware has been selected, check routes that you want to transfer from the equipment to the software (check where it says: Equipment Content).

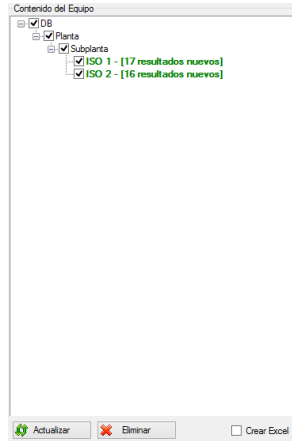

In the event that you want to select or deselect all routes, you must check or uncheck (respectively) the option: Plant.

Note: Routes can be updated (if new ones have been made) by clicking Update icon.

Once routes that you want pass from equipment to software have been defined, you must click on Download icon.

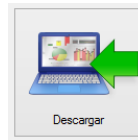

Then wait for selected routes to be saved in software.

Note: Equipment routes can be deleted by clicking Delete icon.

Equipment disconnection

In order to safeguard database files within equipment, it is very important that disconnection of equipment from PC be done safely. To do so, at the end of operation, always use hardware disconnection button

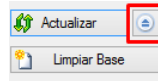

Loading a Route to a file

It may be necessary to upload a path to a device when it is not in the same location as PC where MC software runs. This can be done by generating a file on PC that can later be sent by e-mail or downloaded from cloud and upload it to the laptop manually, to do so you must follow the following steps:

First of all, a folder must be created anywhere on PC that will act as a virtual equipment, then in Portable Equipment tab we select "To a folder"

Then we search for the location of folder using lower icon (highlighted in red) and we will see that, at the top of the screen, under equipment the folder location will appear, select it by clicking so that load icon is enabled, first time this operation is done, it is necessary to execute Clean Base, then select the routes to be transferred and execute Load so that file is generated.

In the virtual folder created previously we will find the following file: [VE_Database.sdf](#)

This file must be sent to location where Expert is located and connecting it to any PC copy this file directly into the SD memory of equipment by clicking on file with the same name that was already inside the SD, in this way Expert will be ready for the execution

of collector routine, to download information operate in the opposite way, that is, return VE_Database.sdf file once route is completed to PC where the MC software is running and download to directory selecting the folder from the main menu

Then simply in Portable Equipment tab select location under Equipment and download

Database Copy

This functionality was generated, as an improvement of the previous one.

In order not to have to go to computer to download VE_Database.sdf file, it can now be generated automatically with this utility. Simply select a destination folder and check copy option so that system, once it downloads data, generates file in selected location.

Visualizations

Clicking on a piece of equipment belonging to a plant or sub-plant displays the "Visualization" window on the right.

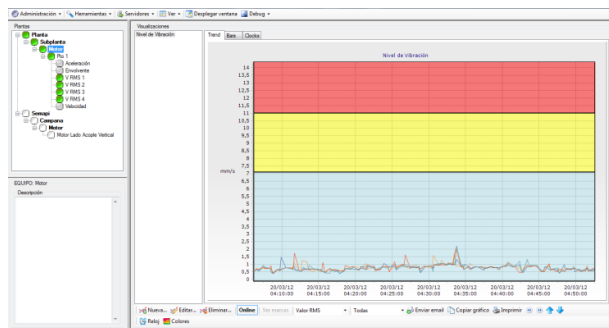

This screen allows vibration level in form of "Trend", "Bar" or "Clock".

To generate a visualization, you must click on "New" icon in menu bar located at bottom of the window, "Create Visualization" window will be displayed where you can generate different views of set of values according to the following premises:

1. Measurements that are added to the same visualization must be of same variable and with similar configurations.
2. Up to 10 measurements can be added in same visualization, these measurements can belong to different points and to different equipment. To add a measurement, double click on corresponding measurement

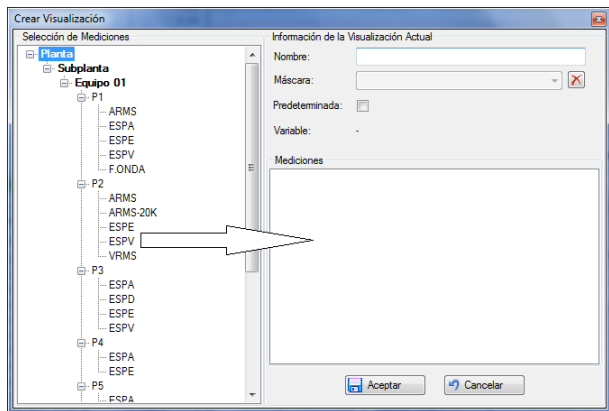

In "Measurements" box, measurements will be displayed in the order in which they were selected.

"Type" option is not yet implemented

Once desired points for this visualization have been added, they must be assigned a name and it is also possible to assign an alarm mask.

Visualization Actual Information

Name:

Type:

Mask:

Default:

Variable:

Measurements

BOMBA A (OESTE) DE SISTEMA REFRIGERACION -> 1H -> ESPV
 BOMBA A (OESTE) DE SISTEMA REFRIGERACION -> 1V -> ESPV
 BOMBA A (OESTE) DE SISTEMA REFRIGERACION -> 2V -> ESPV

Clicking on "Mask" field will display alarm masks already generated and that are compatible with selected measurements.

Click on "OK" option to save this visualization and make it available for use.

Visualization modes

There are three ways to present values on screen:

Trend

Selecting this option, window will show variation of amplitude value of vibration as a function of time, total

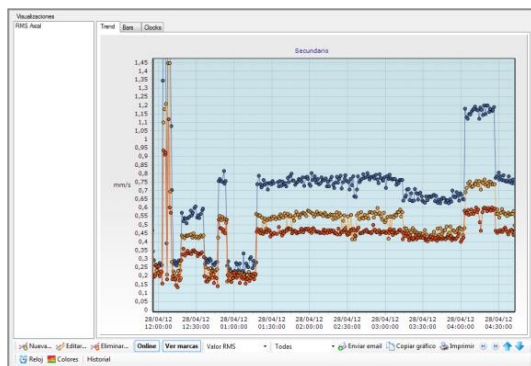

time span shown in window can be selected from option that appears below graph.

Amplitude of displayed value can be selected in the same way from RMS, 0-Peak, Peak-to-Peak, Crest Factor and RPM options if available.

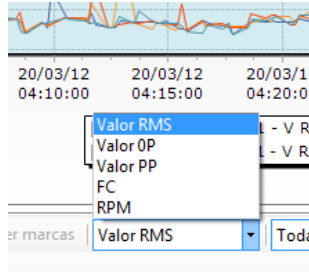

Each amplitude value that appears on the graph is identified by a point of a certain color, linked together by a continuous line of the same color as point, this point can be alternately shown or hidden by clicking on the "View marks" option, if it is hidden, only the evolution of amplitude value will be shown on the graph as a continuous line.

The "View marks" option is activated by default.

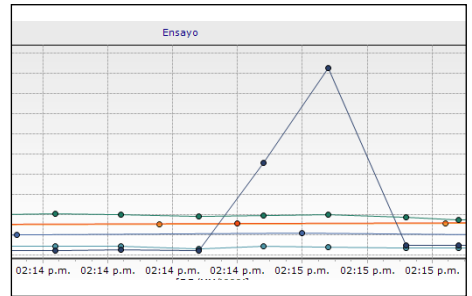
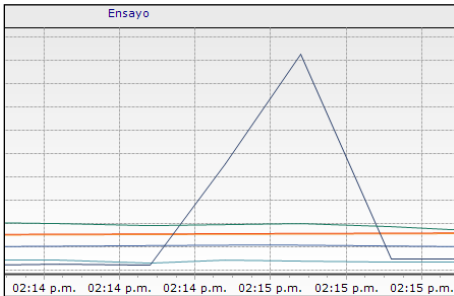

In order to identify the marks and see which measurement is being represented, double click on any part of the graph and detail of points and respective colors will appear.

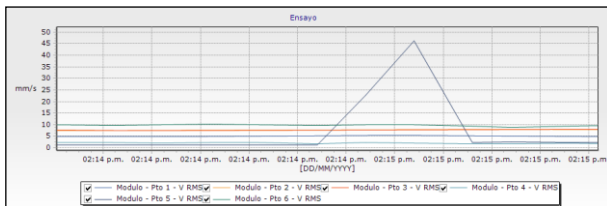

To see a specific part of graph in detail, you can use zoom tool. To activate it, simply click mouse on upper left corner of sector you want to enlarge and drag the mouse to the lower right corner of that sector, to deactivate the zoom you must click and hold anywhere on the graph and drag the mouse to left of its position.

While zoom is applied it is possible to move the graph to left or right to see measurements that were left out of the box by zoom application, simply by clicking on “Back” and “Forward” icons.

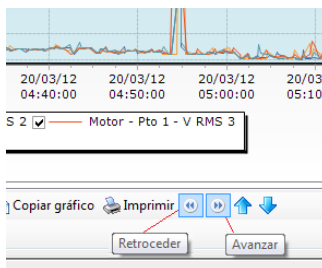

It is also possible to increase or decrease amplitude scale with the “Scroll Up” and “Scroll Down” icons respectively.

Use of Mouse

In "Trend" graph, use of the mouse becomes intelligent, positioning the cursor in the area of graph that you want to expand, turn the mouse wheel and you will achieve a much more dynamic zoom.

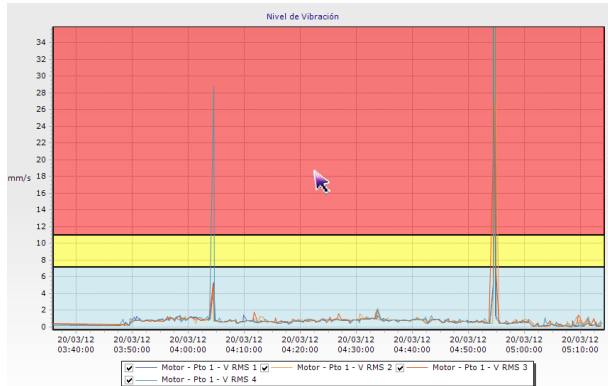

In addition, by clicking on any of the lines that represent values of measurements we can obtain information of value, date, time, equipment, point and corresponding measurement.

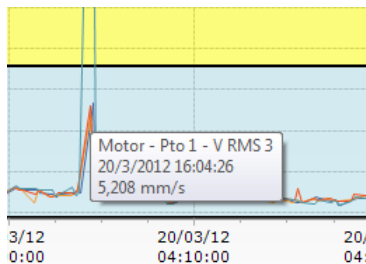

Bar and Clocks

This option will display vibration values in a bar format or an Indicator Clock format as selected

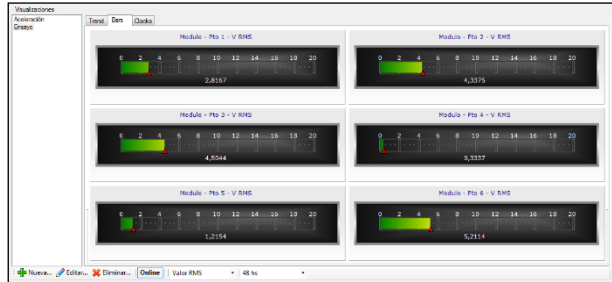

Clock format without alarms



Clock format with alarms



Displayed values will always be the most recent to be measured.

Amplitude of displayed value can be selected from RMS, 0-Peak, Peak-to-Peak, Crest Factor and RPM options if available.

"Send Mail", "Copy Graph" and "Print" options, select image of displayed measurements as it is being displayed and send it by mail to a predefined address, add it to the Windows clipboard so that it is available for pasting in some document or prints it on default printer respectively.

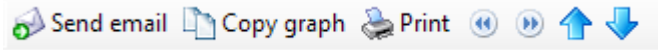

Point Trend

To see trends of all measurements of a point, you simply have to select point in the tree by clicking on that point and trend graphs of all the measurements of point will automatically be displayed on right side of the screen.

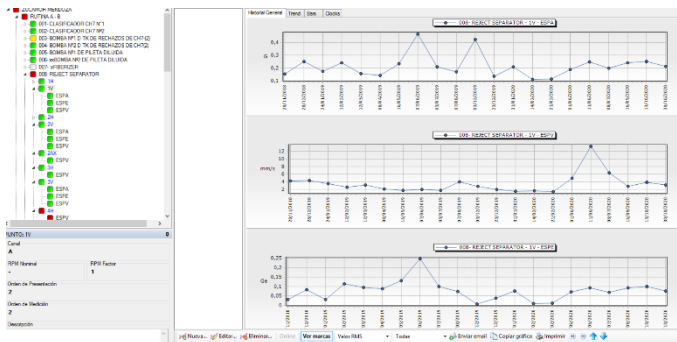

Trend can be seen in RMS, 0-P and P-P values, choosing the value you want to see in the selection box at bottom of screen.

Comments

In this tab you can include "log" type annotations, to be able to keep track of modifications and interventions carried out in the different equipment.

To include a new comment, New button must be pressed. A window opens, where you must select date and enter desired comment

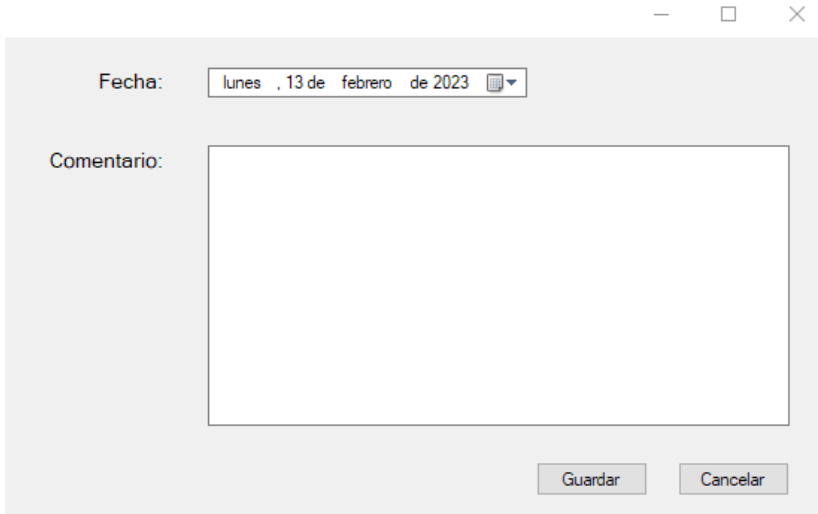

Fecha: lunes , 13 de febrero de 2023

Comentario:

Guardar Cancelar

Once completed, click the Save button.

Comments can be edited or deleted by selecting the desired comment and pressing corresponding button.

Routes

Once the configuration of all equipment in a plant has been completed, in order to carry out a Predictive Maintenance inspection, measurement routes must be prepared. They organize tour in field and order configured equipment to be able to be received by DSP Logger Expert Data Collector.

To manage routes, you must enter this section through access located in one of tabs of main window of program:



Creating and editing Routes

To create a new route, it will be necessary to give it a name.

It is extremely important when creating a route to know the order in which Data Collector operator will measure the equipment in the field. This will undoubtedly optimize data collection time.

When accessing "Routes" tab, main window shows different options for managing routes that can be viewed at bottom of window.:

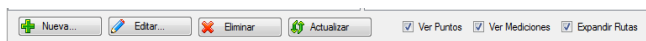

To create a new route, once corresponding icon is activated, right section of screen will be enabled, which will allow us to create a new route.

Here we must assign a name to route (mandatory field) and a description (optional), it can also be assigned a periodicity that is set to 30 days by default.

Then we can see a box on the right where all the equipment available in plant is located, to generate the new route it will only be enough to select the equipment that will form the new route and transfer them to the box on left.

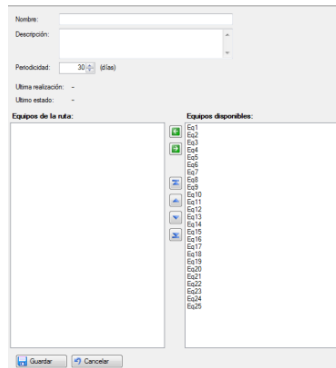

This can be done easily by using “Shift” or “Ctrl” keys to select equipment or simply by double-clicking on that equipment that you want to incorporate into route.

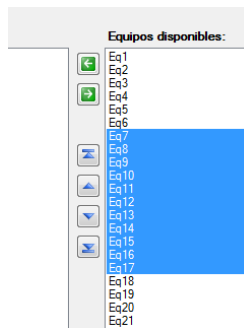

Then with green keys,  we can move selected equipment to the box on left and thus incorporate them into new route.

Blue keys allow us to correct the order of a particular equipment within the route, thus being able to establish order in which equipment's will be measured in field automatically.

Once creation of route is considered finished, we must click on "Save" to finish operation.

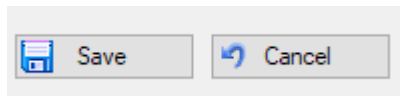

"Cancel" option closes window without saving the

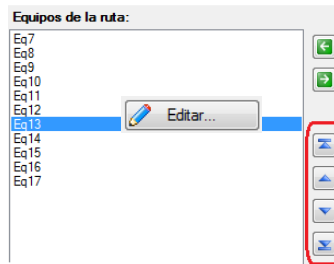

route. Routes can be edited at any time to change order or amount of equipment's.

It is also possible to delete a route directly, to do this, simply select it by clicking on the name of route and then click on "Delete"

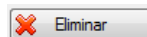

"Update" key shows in routes tree all routes that the plant has, including those that have been created most recently and changes introduced in configuration of different equipment that make up each route.

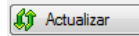

Finally, we can modify display of route tree by selecting detail levels of equipment that makes up route, that is, we can choose to see a device with its points and measurements (this will generate a heavily loaded tree) or only see the codes of Equipment's.

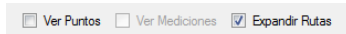
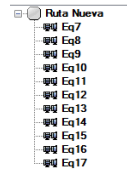

Report

PC connection to download Report

To carry out this process, it is necessary to enter Utilities module:



Activate connection function with icon:



Hardware will wait for USB cable to be plugged into a port on a PC.



Important: If USB cable is connected before enabling this function, hardware connection may not be accessed with software.

Download Equipment Reports

You must access Report's tab to be able to download equipment's content.

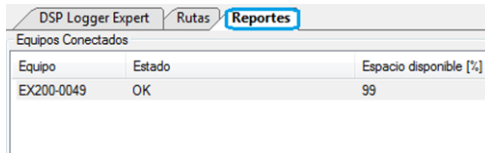

Equipo	Estado	Espacio disponible [%]
EX200-0049	OK	99

Note: to update connected equipment (by reading its database), you must click Update.

If you want to clean computer's database, click on Clean Database.

Once connected Hardware has been selected, click on Download to be able to download all reports



contained in equipment.

Then you must click yes, when software asks if you want to download all reports of equipment. To finish, wait a few moments to be able to view them, according to reports made by each module of the equipment.

Note: in the box below, you can see reports made with the following data: Date/Time, Type, ISO 10816 Class, Code, Name, Point, Comment, RPM, Bearing

Brand and Model; of each channel. To observe all the features, they can be viewed by moving side scroll bar.

In the screen on right you can see details of measurements made, name of field and value or name of each variable analyzed.

Fecha / Hora	Tipo	Código A	Nombre A
15/10/13 11:38:59	Análisis de Rodamientos	A	A
25/09/13 23:52:39	Análisis de Vibraciones	M	M
25/09/13 23:52:17	Análisis de Vibraciones	M	M
25/09/13 23:51:35	Análisis de Vibraciones	M	M
27/08/13 15:57:36	Análisis de Vibraciones	A	A
27/08/13 15:56:18	Análisis de Vibraciones	A	A
27/08/13 15:55:01	Análisis de Vibraciones	A	A
27/08/13 15:54:50	Análisis de Vibraciones	A	A
27/08/13 15:54:41	Análisis de Vibraciones	A	A
27/08/13 15:54:01	Análisis de Vibraciones	A	A

... Tipo: Medidor y Analizador ▾

At bottom of this screen, there is a box that says: Type. This allows you to restrict what type of module you want to observe and analyze.

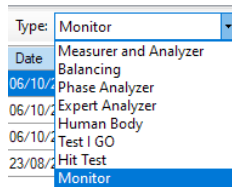

Analysis of Spectrums, Waveforms and/or Orbital Graph

In order to observe and analyze measurements of reports obtained with equipment, you must click on

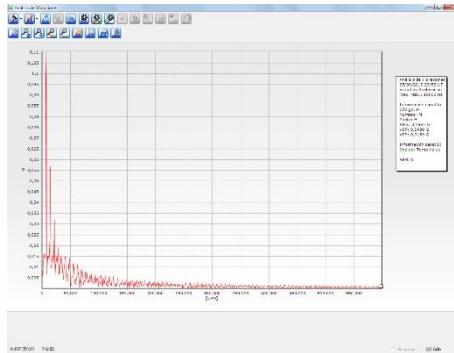

one of them, and software allows you to display graph (spectrum, waveform or orbital graph) corresponding to the measurement of module used.



Example: in Vibration Analysis module, you can see the spectra obtained for each of the measurements taken with equipment.

Chart Comparison

Allows selection of spectra to perform their observation or analysis, regardless of their location in configuration tree.

To include a graph in comparison, it must be positioned over a record and corresponding option is accessed with right mouse button.

Portable Equipments	Routes	Visualization	Graphic
Date	State	RMS Value[m/s]	
05/27/2022 10:02:15	Normal	3.40	
04/26/2022 07:52:22	Normal	4.90	
03/25/2022 12:07:42	Normal	5.96	
02/24/2022 08:40:03	Normal	4.41	
01/20/2022 08:08:27	Normal	3.44	
12/27/2021		8.84	
11/25/2021	Delete Result	3.33	
09/23/2021	Graphics comparison	5.27	
08/24/2021	Move Measure	5.67	
06/24/2021 13:30:26	Normal	4.55	
05/20/2021 13:30:33	Normal	2.80	

After this selection, records that can be added to comparison are restricted. They must have the following characteristics:

- I) It must be the same variable measured
- II) It must have the same maximum frequency
- III) It must have the same number of lines

Once records are selected, all analysis tools, which are described in Analysis Tools section, are available to analyst.

System Menu

At top there are 4 options that allow various configurations.

Administration

With following submenus.

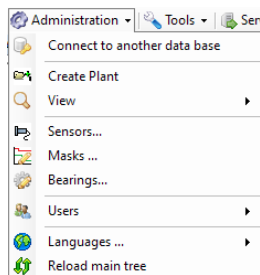

Connect to another database

Allows you to close current database and switch to another.

Plant creation

In case you want to have a second plant in database, you can generate it with this button.

View

Allows you to expand configuration tree to selected option.

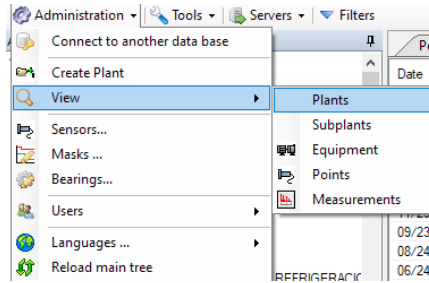

Sensors

DSP Machinery Control software allows you to manage measurements transmitted by hardware connected to system, regardless of the family of machine it controls. All hardware associated and connected to network will be managed by software.

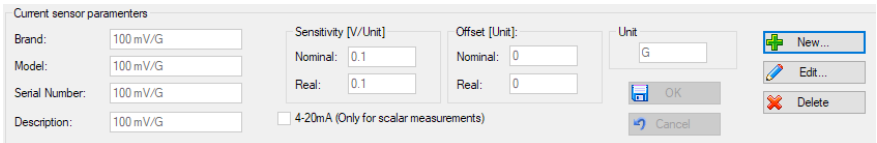
A screenshot of the 'Current sensor parameters' dialog box in the DSP Logger Expert software. The dialog box has a light gray background and contains several input fields and buttons. On the left, there are four input fields for 'Brand', 'Model', 'Serial Number', and 'Description', each with a text box containing '100 mV/G'. In the center, there are two columns of input fields for 'Sensitivity [V/Unit]' and 'Offset [Unit]'. Each column has 'Nominal' and 'Real' fields, both containing '0.1'. Below these fields is a checkbox labeled '4-20mA (Only for scalar measurements)'. On the right, there is a 'Unit' dropdown menu showing 'G', and three buttons: 'New...' (with a plus icon), 'Edit...' (with a pencil icon), and 'Delete' (with a minus icon). At the bottom right, there are 'OK' and 'Cancel' buttons.

Note: this application will only take effect when software is connected to a DSP Remote Monitor, either Compact WRM or Full Condition, it does not apply to the DSP Expert where sensors are configured directly on equipment.

This section of program is normally configured by System installer, when entering the "Administration" option from menu bar and then choosing "Sensors" option from submenu, a window is displayed that allows us to incorporate a new sensor into the system, edit the characteristics of an existing sensor

or delete a mistakenly incorporated sensor from system.

To register a new sensor, click on "New" and then complete all data that is normally printed on sensor certification. Once these fields are completed, click on "Accept" and these data will be ready to be used as response of chosen sensor when configuring measurement point. It is very important to note that the Real Sensitivity field must be completed exactly with data provided by sensor manufacturer, since correct calibration of corresponding point measurement depends on this data.



In addition, this field must be expressed in volts, for example, if sensor's technical chart indicates a sensitivity of 96.4 mV/g, 0.0964 must be entered in Real sensitivity field and g must be entered in Unit field.

Brand, Model and Serial Number fields will be the identifiers of a particular sensor, if these data are not known, they must be completed with generic information such as: Accelerometer, Universal and S/N, for example.

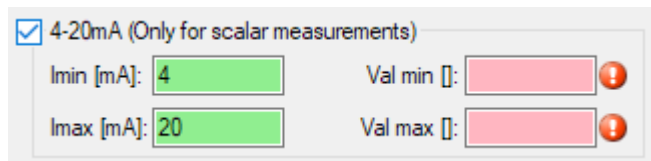
4..20 mA sensors may also be entered. To do this, option is selected and the corresponding configuration box will appear, where Imin and Imax values can be scaled to the minimum and maximum values according to chosen Unit.



4-20mA (Only for scalar measurements)

Imin [mA]:	<input type="text" value="4"/>	Val min []:	<input type="text"/>	
Imax [mA]:	<input type="text" value="20"/>	Val max []:	<input type="text"/>	

Do not try to enter a new sensor if you do not know its sensitivity, since an erroneous data in this field will

undoubtedly generate an error in measurement amplitude.

Alarm Masks

System has the possibility of configuring mask values that trigger alarms, both in spectral measurements as well as in scalar values, these two alarms type can be used one at a time or both can be configured in one measurement.

Creation of mask can be done by experience, by known trend levels in machine when vibration history is available, and by international vibration standards.

If it is intended to fit mask as effectively as possible from first measurement the determination of the mask shape can be relatively complicated and is machine dependent on normal variation in spectral vibration levels at various frequencies. That can only be determined by examining a series of historical spectra, with application of good judgment and knowledge of the machine.

Mask Creation

Before starting to configure measurements, it is convenient to define some alarm masks, both for scalar values and for spectrums. These masks are the ones that will define measurement states and when time comes, they will activate relays to generate assigned action if system is linked to a Remote Monitor module.

To generate new alarms, we must enter to "Administration" option in menu bar and then choosing "Masks" option from submenu, a window is displayed that allows us to incorporate a new mask into system, edit values of an existing mask or delete masks.

Nombre	Tipo	Variable	Sist. Unidades	Unidad	Precaución	Emergencia	Frec. Máx.	Modo
Ensayo	Valor	Velocidad	Metrico	mm/s	2,9	4,4	...	Normal
EspA - 10KHz - 4 Zonas	Espe...	Acelera...	Metrico	G	10000	Normal
EspA - 1KHz - 3 Zonas	Espe...	Acelera...	Metrico	G	1000	Normal
EspA - 1KHz - 3 Zonas (m/s ²)	Espe...	Acelera...	Metrico	m/s ²	1000	Normal
EspA - 1KHz - 4 Zonas	Espe...	Acelera...	Metrico	G	1000	Normal
EspV - 200Hz - 4 Zonas	Espe...	Velocidad	Metrico	mm/s	200	Normal
Estandard ISO 10816-3	Valor	Velocidad	Metrico	mm/s	7	11	...	Normal

Clicking on "New" opens a second window that will allow us to configure the mask.

You must enter a name that is representative and then define whether the mask is for a scalar value or a spectrum, then define variable, unit system and finally the values chosen for level of caution and emergency.

If mask is scalar, values can be defined for RMS, 0-Peak, Peak-Peak, Crest Factor or even RPM measurements.

Create Mask

Name:

Type:

Variable:

Syst. units:

Unit:

Inverted Mode:

Warning:

emergency:

OK Cancel

If mask is scalar, values for measurements can be defined. If a mask is to be generated for a spectrum, precaution and emergency values must be defined for different frequency steps, always defining the cut-off frequency of each step. It is important to note that the last designated frequency step must match the selected maximum frequency RMS, 0-Peak, Peak-Peak, Crest Factor or even RPM.

By clicking “OK” this mask will be saved and ready to be assigned to a measurement, display or relay activation.

Bearings

In this section you can view and/or configure bearing failure frequencies (data for main models and brands are available, but new ones can be added).

Marca	Modelo	Factor BPF1	Factor BPF0	Factor BSF	Factor BTF
BARDEN	100	4.4041	2.9599	1.767	0.3708
BARDEN	101H	5.6479	3.3521	1.7702	0.3725
BARDEN	101	4.9305	3.0795	2.0128	0.3869
BARDEN	101H	6.1362	3.8638	2.0156	0.3864
BARDEN	102	5.3922	3.6078	2.3697	0.4009
BARDEN	102H	6.5769	4.4231	2.3721	0.4021
BARDEN	103	5.8946	4.1054	2.6458	0.4105
BARDEN	103H	7.6485	5.3515	2.648	0.4117
BARDEN	104	5.402	3.998	2.342	0.3998
BARDEN	104H	6.9086	4.4114	2.4444	0.401
BARDEN	105	5.8629	4.1371	2.7496	0.4137
BARDEN	105H	7.6077	5.3923	2.7517	0.4148
BARDEN	106	6.3951	4.6049	2.9254	0.4186
BARDEN	106H	8.126	5.879	3.9274	0.4196
BARDEN	107	6.3807	4.6193	2.9761	0.4199
BARDEN	107H	8.6859	6.3141	2.9781	0.4209
BARDEN	108	6.8627	5.1373	3.3313	0.4281
BARDEN	108H	9.7068	7.2932	3.3331	0.429
BARDEN	109H	9.2268	6.7732	3.0763	0.4233
BARDEN	110	7.4313	5.5687	3.3433	0.4284
BARDEN	110H	10.3794	7.7066	3.346	0.4293
BARDEN	111	6.9009	5.0991	3.1837	0.4249
BARDEN	111H	9.7604	7.2396	3.1856	0.4259
BARDEN	112H	10.2465	7.7534	3.42	0.4307
BARDEN	113H	10.7353	8.2647	3.6515	0.435

To incorporate a new bearing, brand must first be selected (if it does not exist, first select brand registration button).

Then fill in necessary information.

Users

Not used in this implementation.

Languages

Allows you to change language of all screens.
Possible selections are:

- 1) Spanish
- 2) English
- 3) Portuguese
- 4) Chinese

Main tree update

Perform a refresh of configuration tree

Tools

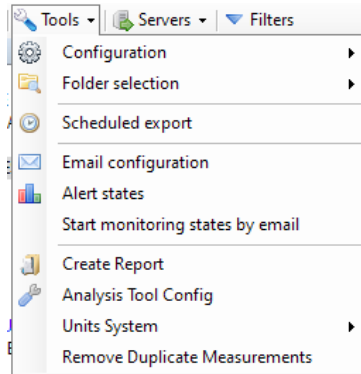

Configuration

Not used in this implementation.

Directory Selection

Selects DSP Machinery Control default location of databases and reports output.

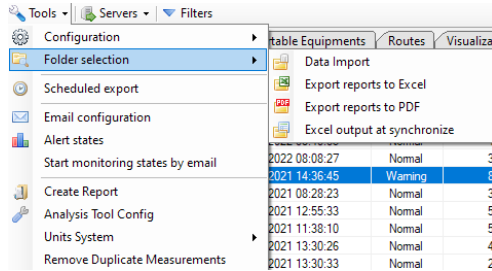

Periodic export

It is used for the configuration of automatic data download in case of continuous monitoring.

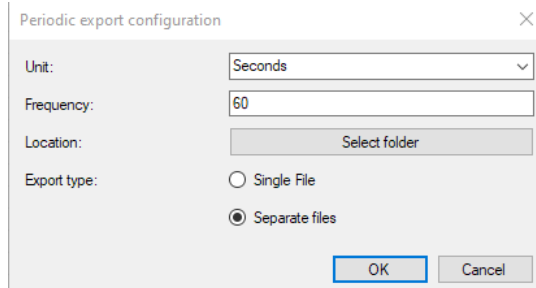

Time unit, frequency, folder and type of export must be selected.

E-mail account

It is used for configuring mailbox, sending reports and/or alarms.

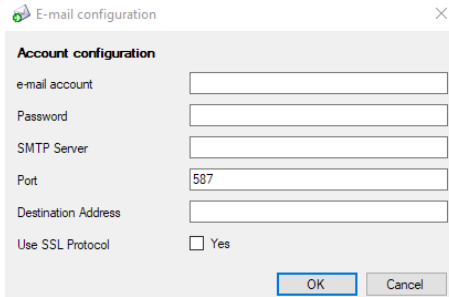

Status alert

It is used to configure automatic sending by e-mail, according to selected frequency of statuses or status changes (according to selection).

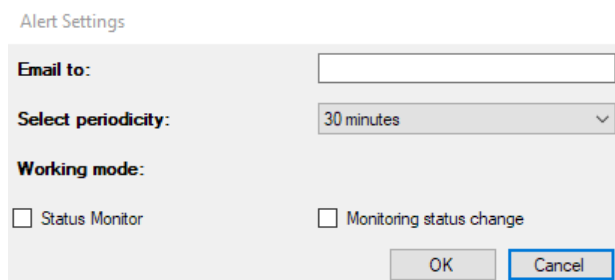

Start status monitoring by email

Enable / disable status monitoring and email reporting (according to previous settings).

Create Report

See Report section.

Configure analysis tool

See section **Main cursor marking icon**.

System units

Allows you to select between Metric and Imperial and modifies default Measurement's creation option.

Delete duplicate measurements

for cases in which duplicate measurements are found in results tree, system can eliminate them. To do this, select corresponding option.

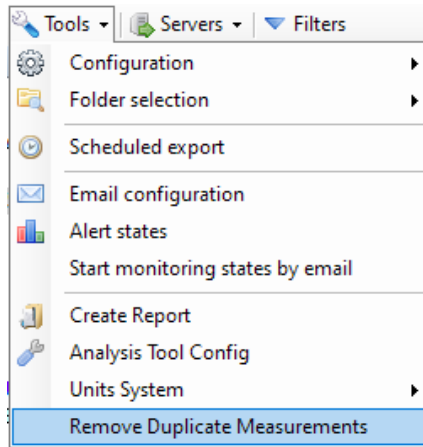

Servers

Not used in this implementation.

Tree configuration

System will save all information collected in the same file, in order to manage data, a tree will be generated whose upper level is generically called "Plant"

Defining one or several plants will depend on the number of machines that will be under control. If there are not too many, creating a single plant may be convenient since all the machines will be in a single location and consults and measurement comparisons will be simpler and more direct, but if

there are a large number of machines to be controlled (more than 100, for example) then generating more than one plant or generating sub-plants can make the measurement control more orderly.

Plant

To create a plant, simply enter "Administration" option on menu bar and then choosing "Create Plant" option from submenu, a window is displayed that allows us to incorporate a new plant into system. Mandatory field is Name, but additionally a Description, Link (which works as a Web link) and geographic data (Latitude and Longitude) can be added if considered necessary.

The 'Create Plant' dialog box is a standard Windows-style window with a title bar. It contains the following fields and controls:

- Name:** A single-line text input field.
- Description:** A multi-line text area.
- Link:** A single-line text input field.
- Location:** A label above two single-line text input fields for Latitude and Longitude, each with a dropdown arrow on its right side.
- Buttons:** 'OK' and 'Cancel' buttons at the bottom.

This location can be edited to suit the physical location of system, to do so just click on "Plant" and then right click and select "Edit", then simply change name to desired one.

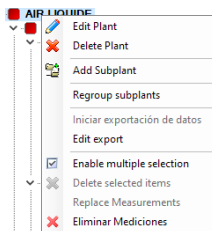

Subplant

It is necessary to create a lower level in the tree called "Subplant", this level can include several machines to be measured, if these machines are installed in the same sector of plant, it would be advisable to generate these machines in the same Subplant, they can be generated as many sub-plants as necessary.

Keep in mind that inspection routes are carried out at sub-plant level, so all the equipment that you want to measure on same route must belong to the same sub-plant.

To generate a Subplant, just click on "Plant", then right click and choose the option "Add Subplant" enter name in pop-up window and accept it.

Within Subplant editing options are: Name (mandatory) and Description.

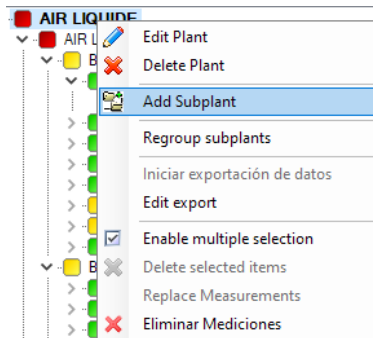

Equipment

Once Subplant has been created, rotating equipment that you want to control can be generated, following the same procedure we select Subplant and with right click choose "Add Equipment"

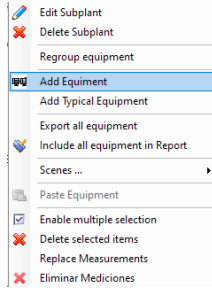

To create an equipment, simply enter a Name. Additionally, Description and Tag can be added, it is also possible to associate the equipment to a digital photo or a graphic file by generating a link through "Scheme" or "Photo".

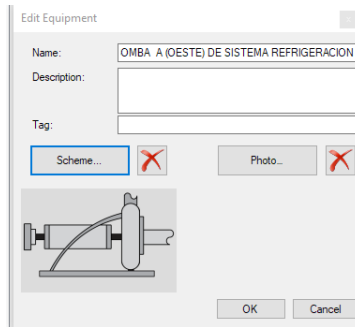

Scheme can be a plan with general lines of equipment, when a scheme of a team is incorporated, measurement points can be identified when creating them.

System has some schemes, which can be selected to incorporate it into equipment.

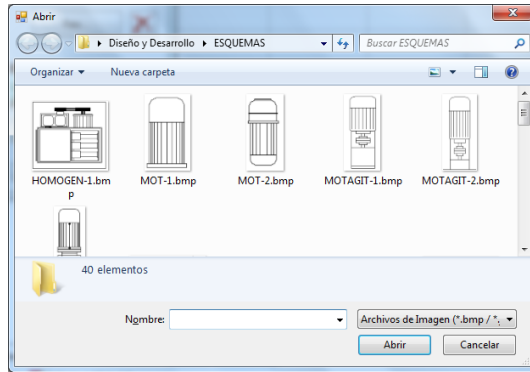
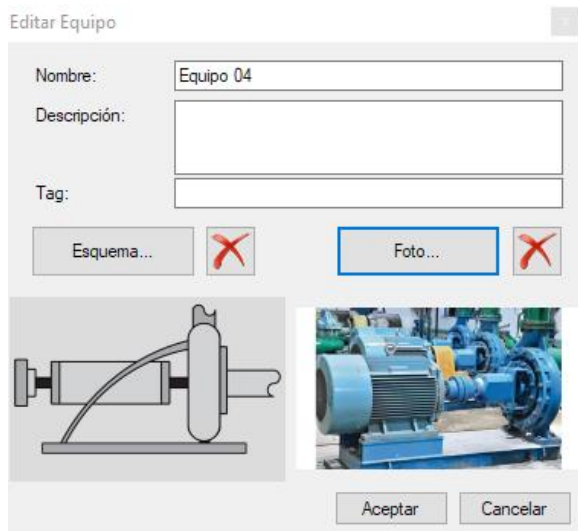
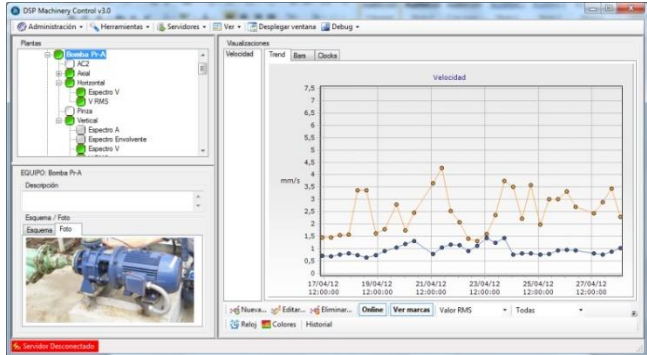

Photo is an image that should be, in principle, particular to equipment, this can help to identify it with other similar machines.



These graphs can be seen in a device measurement display query, as shown in window:



Copying Equipment, Points and Measurements

System allows you to copy Equipment, Points or Measurements very quickly and easily, just right click mouse on element you want to copy, select copy option and then paste the element where required, always within the same Sub-plant, in this way a measurement can be copied and pasted into any other point, a point within another piece of equipment and a piece of equipment within the same sub-plant.

Equipment copying has one more option, which is to copy various equipment, in this way, if we find several similar equipment in a sub-plant, it will be enough to create one equipment and duplicate it as many times as necessary.

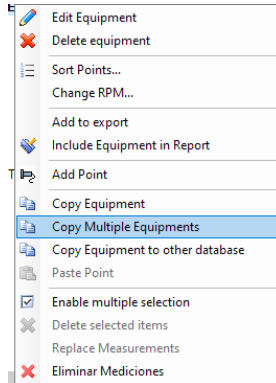

After selecting Copy Multiple Units option, a dialog box opens that asks me to enter the name of the units to copy

Then, with a right click on the Subplant, select Paste equipment and all duplicate equipment will be created

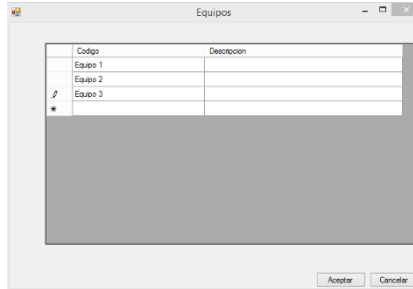

Copy or Move an equipment to another Database

It is possible to copy or move an equipment to another database, with a right click on the equipment to copy select copy Equipment to another Database

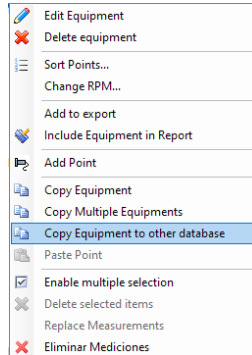

A dialog box opens where I choose the following selections:

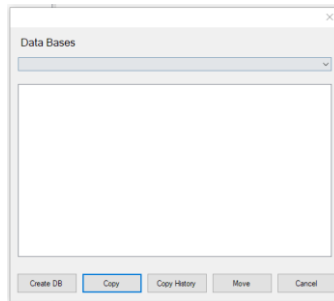

- Create DB: Allows the operator to create a new destination Database.
- Copy: Will copy equipment configuration to destination base.
- Copy History: Will copy equipment configuration and existing measurements to destination base.

- Move: Equipment with its measurements will move to the new chosen base, ceasing to exist in the original base.

Point

Following the same procedure selecting equipment and right clicking we can then create a measurement point.

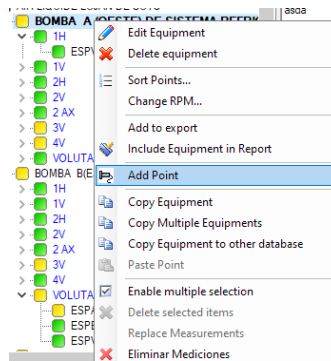

Clicking on "Add Point" displays a window where by default the system assumes that point to be created

The 'Create Point' dialog box is shown with the following fields and options:

- Type: Remote Monitoring, Portable Equipment
- Hardware: [Dropdown]
- Channel: [Dropdown]
- Sensor: [Dropdown]
- Name: [Text Field]
- Description: [Text Area]
- Tag: [Text Field]
- RPM Nominal: [Spin Box, value 0]
- RPM Factor: [Spin Box, value 1]
- Buttons: Define point in drawing..., Place point in picture
- Presentation order: [Spin Box, value 1]
- Order of measurement: [Spin Box, value 9]
- Bearing: [Text Field]
- Bearing #1: [Text Field]
- Brand: [Dropdown, value None]
- Model: [Dropdown, value None]
- Buttons: OK, Cancel

belongs to DSP Logger Expert, if the point belongs to a Remote Monitor module check the corresponding box.

Once this selection is made, Hardware field is disabled and channel to which sensor is going to be connected must be selected to measure the point to be created. If a standard acceleration sensor is going to be used, channel A or B must be selected (usually channel A), if a triaxial sensor is to be used, input corresponding to direction in which this point will be

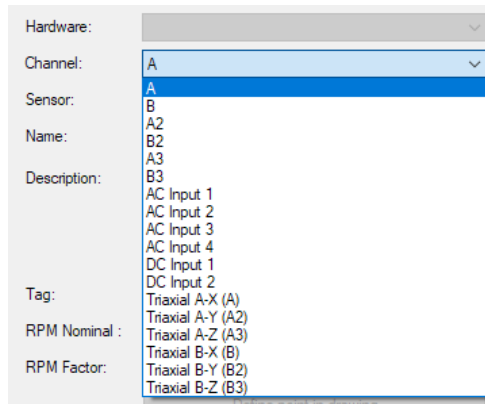

measured must be selected (Triaxial A-X (A) for example).

If you want to make a measurement with another type of sensor with alternating voltage output, such as an amperometric clamp, inputs AC1 to AC4 must be selected, and if what is going to be measured is a sensor with direct voltage output (for example, temperature) or a manual input data, input CC1 or CC2 must be selected.

To finish with creation of a point, it must be given a name, generally related to the position of sensor, it is also possible to add a description so that location of point in equipment to be controlled is clearer.

As additional information, a more general description can be added, RPM and up to 6 bearing data, if applicable. These last two items are of great help in analysis since frequencies of bearing failures and others will be calculated from them.

RPM Nominal : 1490
RPM Factor: 1
Define point in drawing
Place point in picture
Presentation order: 1
Order of measurement: 1
Bearing #1: Brand: NDH, Model: 1216
Bearing #2: Brand: SEA, Model: E-FB27/16
Bearing #3: Brand: , Model:
Rodamiento #4: Marca: Ninguno, Modelo: None
Rodamiento #5: Marca: Ninguno, Modelo: None
Rodamiento #6: Marca: , Modelo:

Define measurement points on diagram and on photo:

From buttons define points, you can graph the exact

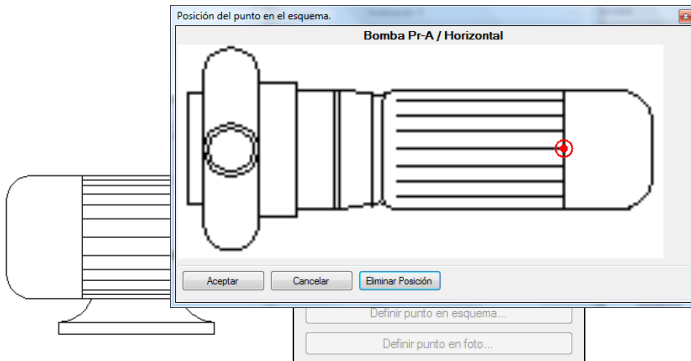

position where sensor of measurement point is located or where it should be placed.



This operation must be repeated at each point, the first time the equipment is configured or from the moment appropriate diagram or photo is available.

Presentation Order field defines how point is located in main tree. If presentation order is left with value 1 for all points, presentation order will be alphanumeric. This field can be edited at any time.

Finally, we have the Measurement Order field, this field will indicate the order in which generated points will be measured, if for all points measurement order is left with value 1, measurement order will respect the order in which points were created.

This field becomes very important when making measurements with a triaxial sensor, since for system to make measurements in three directions of a triaxial sensor, points must have same measurement order.

In this way, an example configuration would be as follows:

Point 1 horizontal: select Channel **Triaxial AX (A)**, **Measurement Order 1**.

Point 1 vertical: select Channel **I Triaxial AZ (A3)**, **Measurement Order 1**.

Point 1 axial: select Channel **Triaxial AY (A2)**,
Measurement Order 1.

Point 2 horizontal: select Channel **Triaxial AX (A)**,
Measurement Order 2.

Point 2 vertical: select Channel **Triaxial AZ (A3)**,
Measurement Order 2.

Point 2 axial: select Channel **Triaxial AY (A2)**,
Measurement Order 2.

Point 3 horizontal: select Channel **Triaxial AX (A)**,
Measurement Order 3.

Point 3 vertical: select Channel **Triaxial AZ (A3)**,
Measurement Order 3.

Point 3 axial: select Channel **Triaxial AY (A2)**,
Measurement Order 3.

Point 4 horizontal: select Channel **Triaxial AX (A)**,
Measurement Order 4.

Point 4 vertical: select Channel anal **Triaxial AZ (A3)**,
Measurement Order 4.

Point 4 axial: select Channel **Triaxial AY (A2)**,
Measurement Order 4.

Measurements

Now you can add a measurement, to do so, just click on the point created and then right click select "Add Measurement"

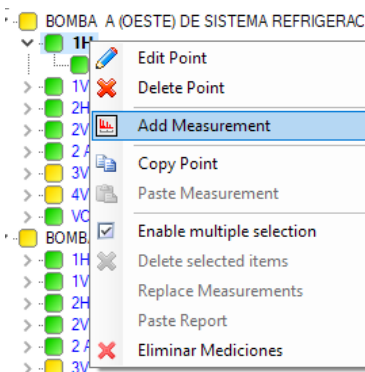

Then a window is displayed that will allow us to configure multiple types of measurements that the system allows. It is very important to get advice on different measurement options, since there will be parameters such as Fmax and line resolutions, which cannot be modified once measurement is created.

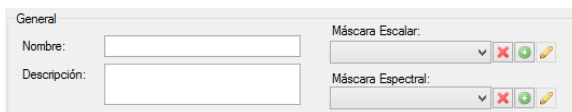

Measurement setup window

In "General" section at top of this window allows you to put a name to this measurement, this field is required, you can also add a detailed description of measurement if desired.

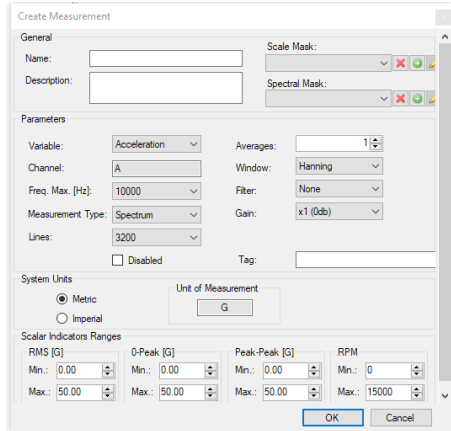

"Scalar mask" and "Spectral mask" fields will allow alarm limits to be established for measurement created, for this it is necessary that an alarm mask that is compatible with measurement has previously been generated (see mask creation), in any case, system has a series of preloaded masks that respond to the most frequent configurations

Alarms that can be selected will be directly related to the configuration of measurement, taking into account the variable, maximum frequency and unit selected, system will only show alarms that can be applied to each measurement.

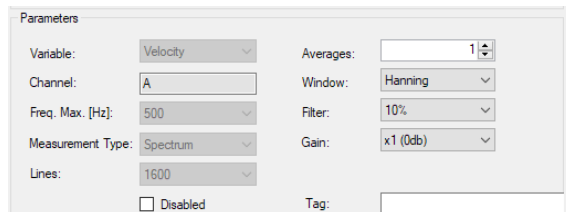

"Measurement parameters" section will allow us to configure measurement itself by completing the following parameters:

Variable

Defines the vibration variable to be used, being able to choose between acceleration, velocity, displacement and envelope.

Channel

This field is automatically filled according to selection made when creating measurement point, it is not editable

Maximum frequency (Hz)

Defines the maximum frequency of measurement to be carried out, a value between 10 and 20,000 Hz can be selected.

Measurement Type

Defines what type of measurement is going to be made, being able to select between scalar values in RMS, 0-Peak, Peak-Peak, Spectrum graph and Waveform graph.

Lines/Samples

This field appears when a Spectrum or a Waveform is selected as type of measurement, it allows choosing spectral resolution between 400 and 25,600 Lines for a spectrum and between 512 and 16,384 Samples for a Waveform

Averages

Defines if an average measurement is going to be performed, allows selecting a value between 1 and 50, defines time span over which measurement is performed.

Temporal extension depends on maximum frequency and chosen averaging.

Window

This field is enabled only when a Spectrum is selected as Measurement Type, it allows selecting from among 3 types of windows, Rectangular, Hanning and Flat Top.

For routine measurements use of the Hanning window is recommended.

Gain

Allows you to activate a signal amplifier (recommended only when signal is of very low amplitude).

You can choose to amplify X1, X5, X50 and X100. **Do not choose large amplifications when high frequency vibration generates high levels of acceleration, this may cause system saturation resulting in erroneous measurements and high noise level, limit the use of amplifier to measurements of equipment with very low turns, where vibration energy does not generate high levels of acceleration.**

Filter

Depending on selected variable, different types of filters will be enabled or not, to measure very low frequencies in "Velocity" or "Displacement" filters can be selected in order to improve signal-noise ratio, these filters are activated depending on maximum frequency and may be 1%, 2.5%, 5% and 10% of said frequency.

Selectable filters are expressed in percentage value, which has to do with the fact that this percentage is applied based on maximum frequency selected.

Example: Fmax, 500 Hz with filter set to 5%, will apply a filter on the 0 to 25 Hz measurement.

In 1% filter, it is applicable to measurements to evaluate state condition according to ISO 10816 standard, this measurement must be configured at Fmax 1000 Hz, applying the 1% filter, frequency response will be from 10Hz to 1000Hz.

Parámetros de la Medición

Variable:	Velocidad	Promedios:	1
Canal:	A	Ventana:	Hanning
Frec. Max. [Hz]:	500	Filtro:	10%
Tipo de Medición:	Espectro	Ganancia:	1% (ISO 10816)
Líneas:	800		2.5%
			5%
			10%

If selected variable is "Envelope" different bandpass filters will be enabled, which can be selected depending on area where you want to generate the demodulation of input signal.

All filters can be used in envelope measurements, as long as it is applicable to selected maximum frequency, in case of filter 5, it is implemented as high pass.

1- 1.250 Hz a 2.500 Hz -3db filter

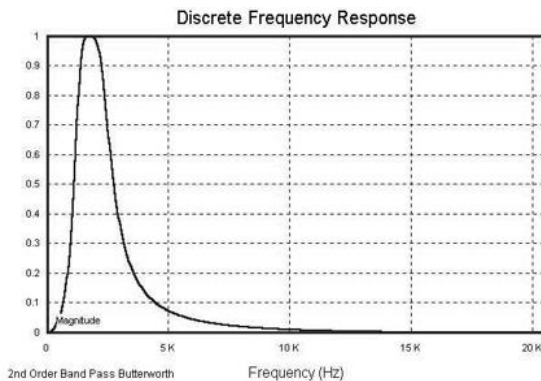

2- 2.500 Hz a 5.000 Hz -3db filter

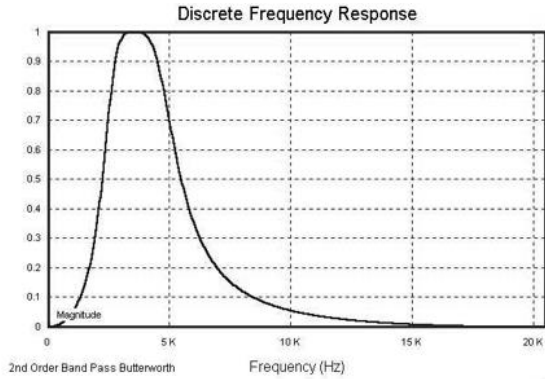

3- 5.000 Hz a 10.000 Hz -3db filter

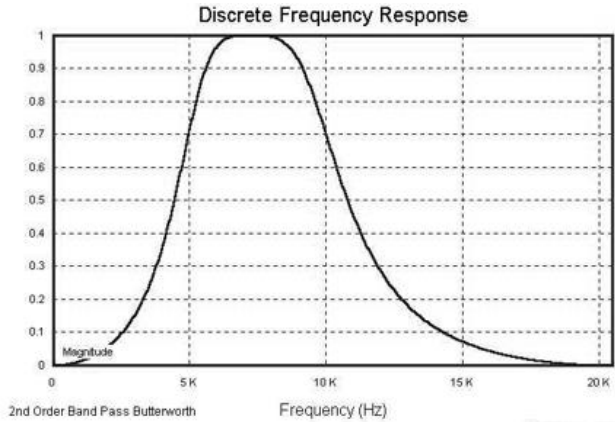

4- 10.000 Hz a 15.000 Hz -3db filter

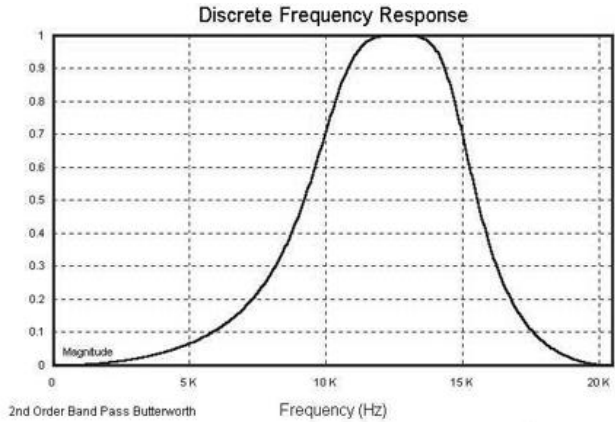

5- 15.000 Hz a 20.000 Hz -3db filter

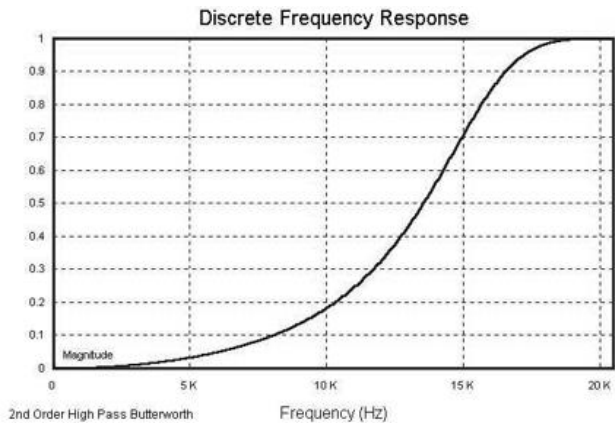

With selection of "Acceleration" as a variable, no filter will be activated.

Unit system

Unit system section simply allows you to choose between metric and Imperial system of measurement.

Sistema de Unidades

Métrico
 Imperial
 Otro

Unidad del Sensor:

Unidad de la Medición:

Range

Finally, section "Ranges of Scalar Indicators" allows you to select full scale for clocks or measurement bars, it is convenient to adjust these indicators to a value somewhat above the maximum expected levels in order to obtain clearer readings.

Rangos de los Indicadores Escalares

RMS [mm/s]	0-Pico [mm/s]	Pico-Pico [mm/s]	RPM
Min.: 0,00	Min.: 0,00	Min.: 0,00	Min.: 0
Max.: 20,00	Max.: 30,00	Max.: 50,00	Max.: 4000

Clicking on "OK" will define measurement according to selected parameters.

AC auxiliary channels

In order to add an alternating current measurement, first thing is to create a point linked to these auxiliary channels 1 to 4.

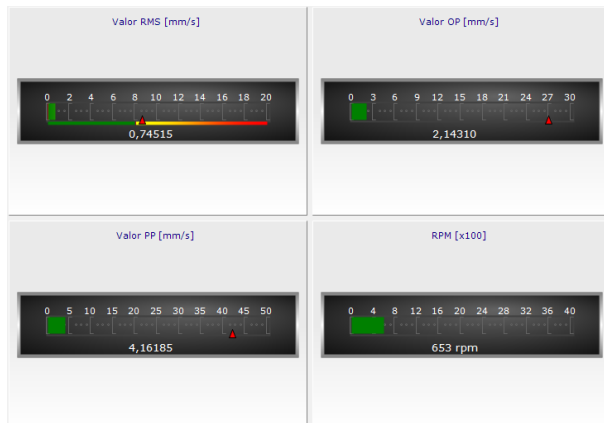

Following the same procedure of other points and right clicking you can create a measurement point.

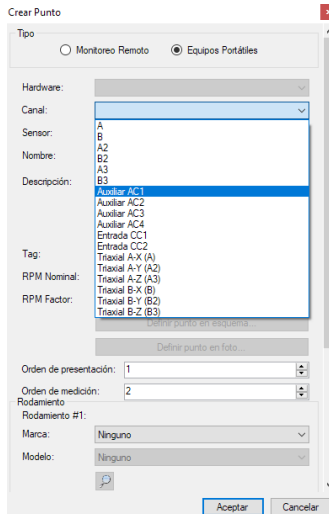
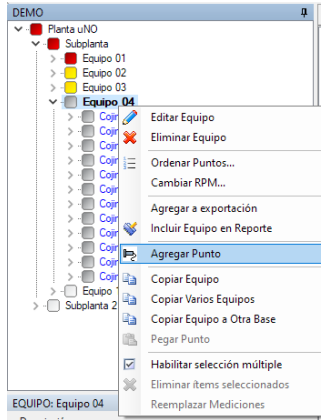

When creating measurement point, some of the Expert's AC inputs must be selected as channels. Normally, standard connector is already configured to connect to AC 3 or AC 4 inputs, so we recommend choosing one of these, for example AC 3, Another

detail to take into account is that you have to tell the system what is going to be measured, so the letter A must be placed in the Unit of Measurement field, indicating that the reading will be done in Amperes. In this way configuration of measurement would be the following:

DC auxiliary channels

In order to add a direct current measurement, first thing is to create a point linked to these channels CC1 and CC2.

Following the same procedure of other points and right clicking you can create a measurement point.

This input can be used to measure a temperature, for example, it is also possible to incorporate data from

process variables with keyboard entry, for this it is enough to mark with a check mark in the "Manual Entry" box and it will be possible to enter by keyboard any numerical variable that you want to incorporate into measurement routine, you must always remember to fill in the Unit of Measurement field.

Include an Off-Route measurement to the tree

A measurement made in analyzer module in the off-route option can be moved to main tree after being downloaded.

To do so, just select the measurement with right mouse click and choose "Move"

Fecha / Hora	Tipo	Código A	Nombre A	Puerto A	Comentario A
17/12/18 10:40:17	Análisis de Vibración				
17/12/18 10:40:48	Spikes Energy Lev				
17/12/18 10:39:55	Análisis de Ruido				
17/12/18 10:39:43	ISO 10816				
04/10/18 16:29:11	Análisis de Vibración				
04/10/18 16:24:59	Análisis de Vibración				
04/10/18 16:22:41	Análisis de Vibraciones	Temp Value			1.220 S

Then in tree view for the point where you want to paste this measurement and selecting it with right click choose the option "Paste Report"

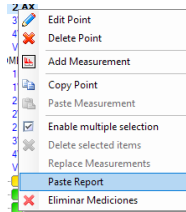

If point did not have a measurement of this type already created, it will be created automatically according to the configuration chosen when measurement was made. If point already had a measurement with the same characteristics as the one to be moved, then it will have to be pasted directly on already existing measurement so that it is added to history

Access to history

To access the history of a particular measurement, desired equipment with its points and measurements must be displayed in main tree, then click on measurement to be consulted in main tree.

Right section of screen has changed and shows the history of selected measurement

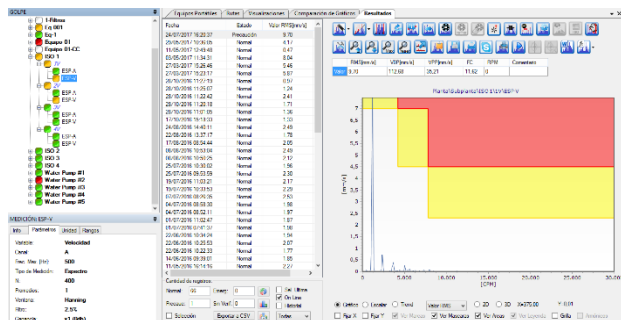

Results list

On the left side of the "Results" window, history of selected measurement is displayed.

Fecha	Estado	Valor RMS [mm/s]
20/03/2012 16:07:41	Normal	0.79
20/03/2012 16:07:29	Normal	0.93
20/03/2012 16:06:49	Normal	0.56
20/03/2012 16:06:37	Normal	0.68
20/03/2012 16:06:25	Normal	0.58
20/03/2012 16:05:45	Normal	0.71
20/03/2012 16:05:33	Normal	1.06
20/03/2012 16:05:21	Normal	0.65
20/03/2012 16:04:41	Normal	0.80
20/03/2012 16:04:29	Emergencia	28.69
20/03/2012 16:03:49	Normal	0.97
20/03/2012 16:03:37	Normal	0.79
20/03/2012 16:03:25	Normal	1.24
20/03/2012 16:02:44	Normal	0.99
20/03/2012 16:02:33	Normal	0.83
20/03/2012 16:02:21	Normal	1.09
20/03/2012 16:01:41	Normal	1.06

Where the list of measurements made by date is observed, with its measured value and its status, status will change from "Normal" to "Caution" or "Emergency" depending on alarm mask assigned to said measurement, if measurement did not have any alarm mask assigned "Status" column will show the legend "Not verified"

of records:

Normal: Emergency:  Sel. Last

Caution: Unverified:  On Line

Multiple Selection  Record



Below the measurement listing are two measurement checkboxes,

By default, these boxes are unchecked.

The number of measurements that will be displayed on "Results" screen can be configured by displaying the field shown below.:

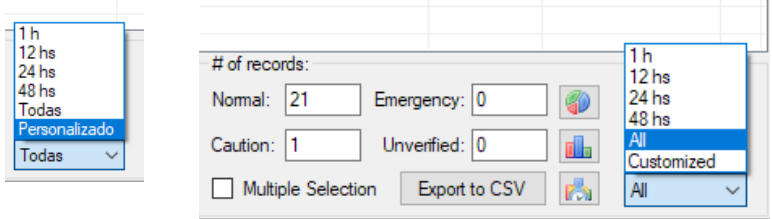

Applying "Custom" option, two calendars are displayed where we can select dates and times between which we want to see measurements made.

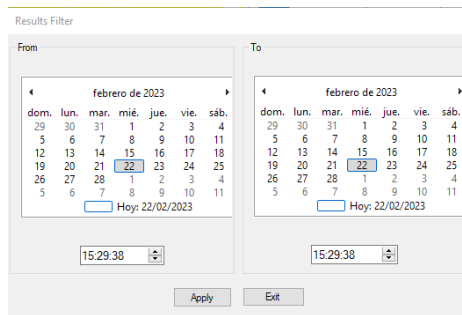

Below listing is a record counter showing the number of measurements per state

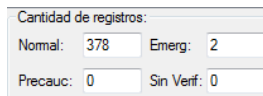

These 3 types of graphic selectors present information on point measurements, when they have a defined status (normal, precaution or emergency).

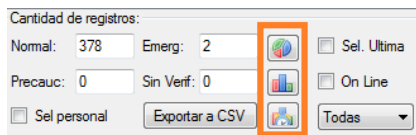

Graph by number of measurements with their states, presented in percentage.

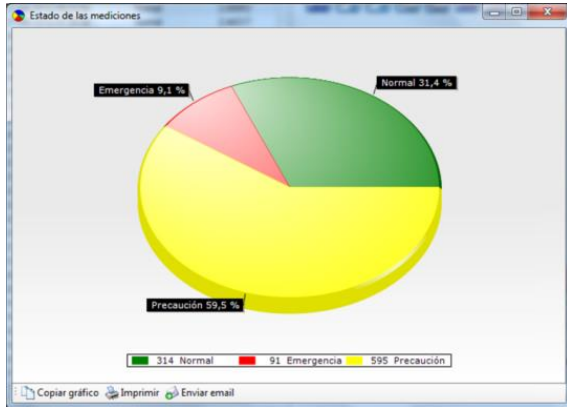

Graph with maximum values by state, maximum value recorded during selected filter, of NORMAL, CAUTION AND EMERGENCY states.

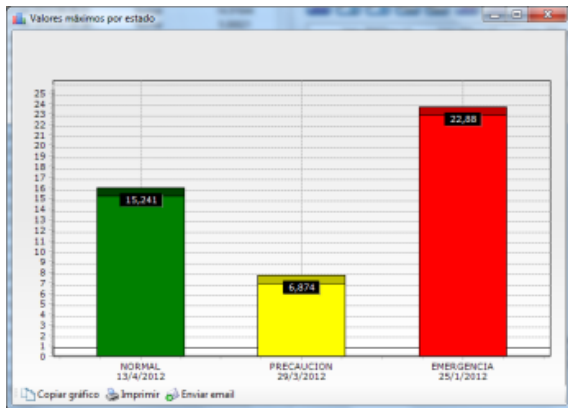

Graph showing maximum values in each hour within selected filter, with color corresponding to state.

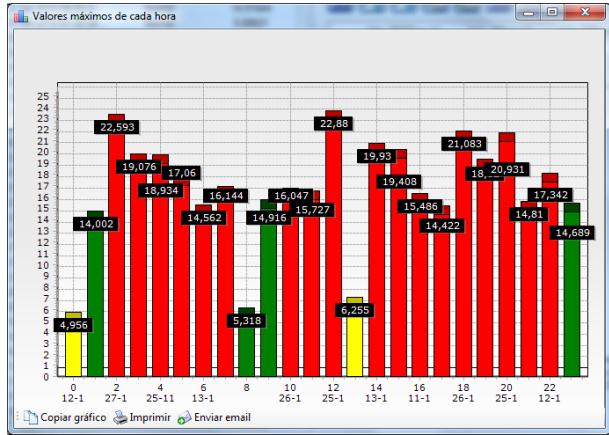

These graphs can be copied to clipboard, printed or sent by mail using the corresponding tools.



CSV Export

It can be exported to a CSV file with information on measurement value, date and status of this measurement using "Export to CSV" tool.

These comma-separated files can be opened with Excel and then made part of a report. Applications are

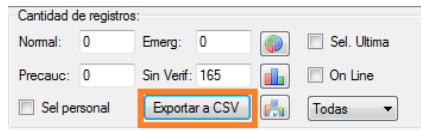

also known with other management programs that can import information from intermediate CSV files.

Results graphs

On the right side of the "Results" window, graph of measurement is shown if it is a spectrum or a

waveform, or the representative bars of values if measurement is a scalar value.

If we are viewing a spectrum, it can be seen in RMS, 0-P and P-P values by choosing desired shape from selection box at bottom of screen.

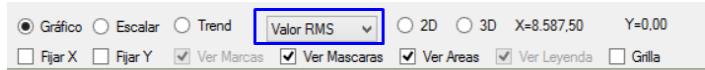

If measurement is scalar, RMS, 0-Peak, Peak-Peak and RPM values (if available) will be displayed using “Graph” (Disabled), “Scalar” or “Trend” checkboxes.

Or in Trend form for any form of amplitude measurement.



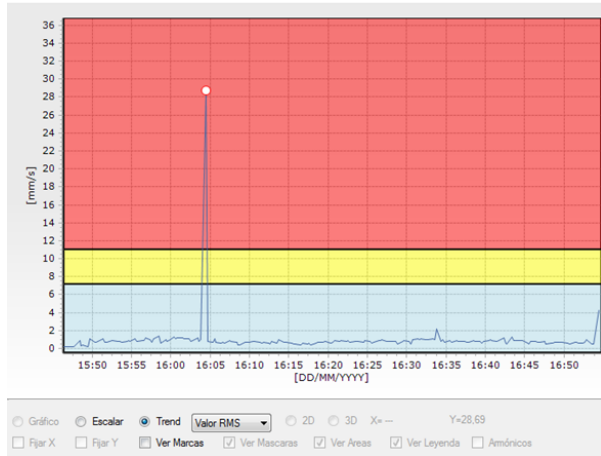

When consulting a spectral measurement, it also allows you to switch the view between spectrum graph and Trend of total value of measurement.



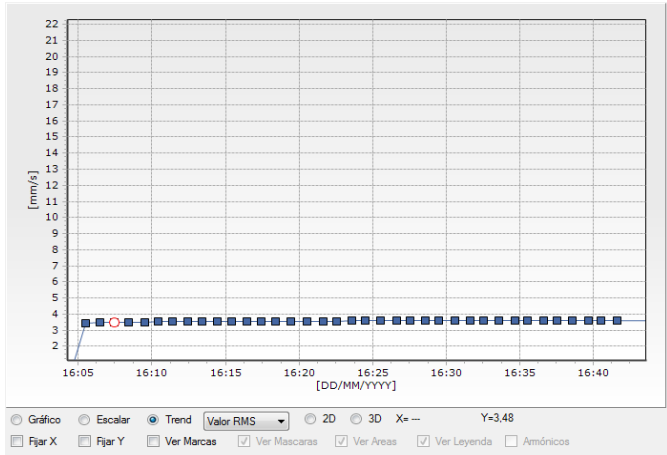

Even in a spectrum you can choose to see scalar values.

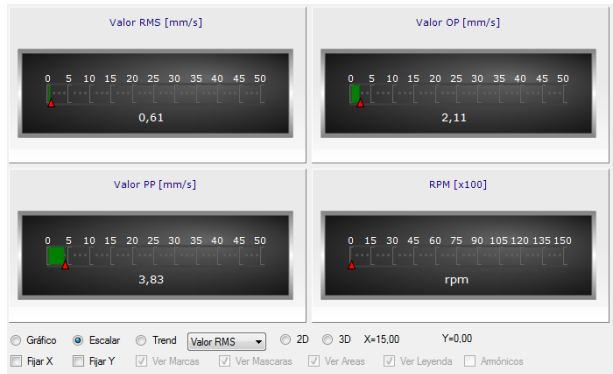

Other tools that can be accessed under the spectral graph are those for comparing 3D and 2D spectra:

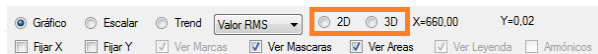

By checking "2D" box, two or more spectra are compared in superimposed view.

To do this, it is enough to hold down the "Ctrl" key and click on measurements that we want to compare from the list on the left.

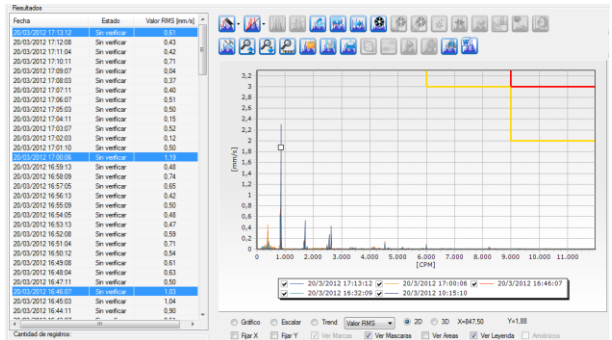

In the same way, cascading comparisons can be made by checking the "3D" box.

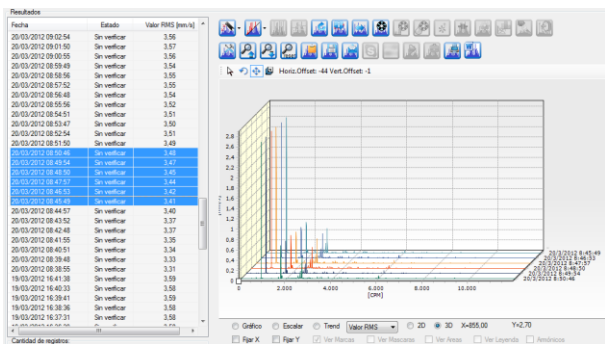

“Fix X” and “Fix Y” checkboxes are useful when we move between different measurements in the list, since they allow us to maintain amplitude and frequency values of a certain view

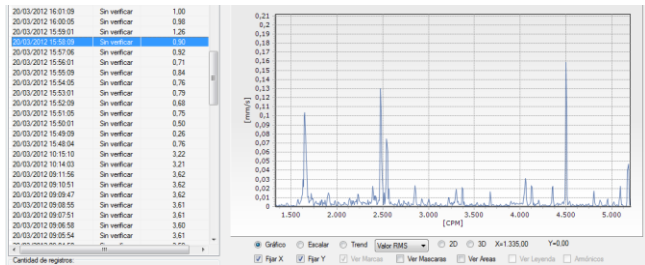

Below the spectrum, "View Masks" and "View Areas" boxes allow you to show or hide alarm masks and paint or unpaint them respectively.

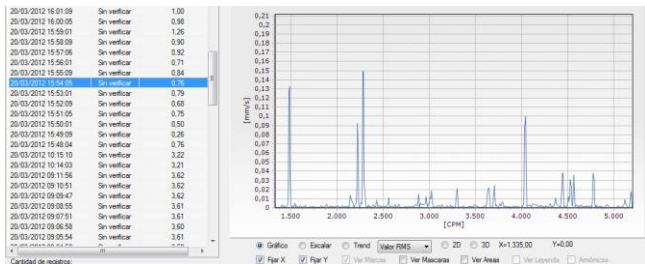

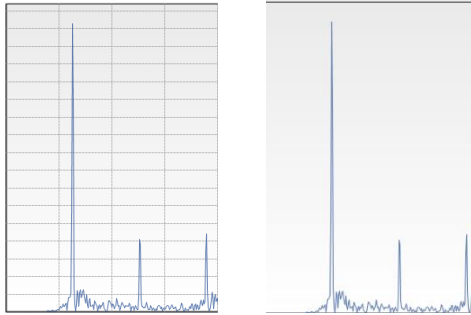

Grid box activates and deactivates reference marks in spectral graph.

Mouse right-click options

Depending on the level we are at (Plant, Subplant, etc.) if we press the right mouse button, we will have different options.

Edit / Delete Plant or Subplant or Equipment or Point or Measurement

To make modifications or delete the content of entire plant.

Add Subplant or Equipment or Point or Measurement

Already explained above.

Group Subplant

Closes configuration tree showing up to sub-plant level only.

Start data export

It is used to enable/disable sending of data when using remote and continuous monitoring systems.

Edit export

It is developed in the Data export section.

Enable multiple export

Checking this item allows multiple items to be selected for later deletion or replacement of multiple measurement settings.

Replace Measurements

This utility is used for multiple modification in measurement configuration.

Suppose we want to make a configuration change for a certain number of measurements (for example, we want to change the measurement window from Hanning to Rectangular). For this we follow the following steps

- 1) We edit 1 of measurements and make the change.
- 2) On measurement, right click and "copy measurement.
- 3) Enable multiple selection.
- 4) We select the measurements we want to correct
- 5) Once they are all selected, with right mouse button "Replace measurements".

Include teams in Report

It is developed in Reports section.

Scenes

Scenes are used for continuous monitoring.

Sort Points

At equipment level, it allows reordering points both in order of measurement and in order of presentation.

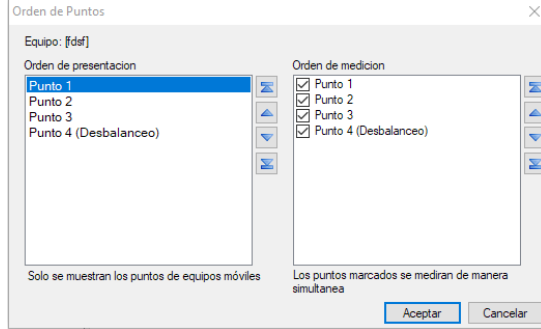

RPM change

At equipment level, it allows editing and/or modifying RPM defined for each point.

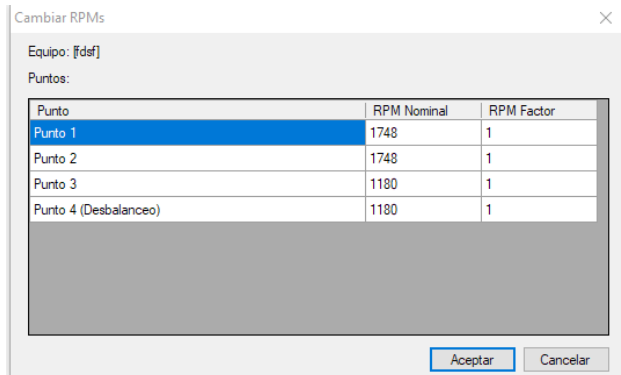

Copy

It is explained in section Copying Equipment, Points and Measurements.

Add to orbital chart

If you have measurement waveform, you can add it to orbital analysis. It is detailed in Waveform Analysis Tools.

Add spectral mask

To be defined.

Data export

Data export is used in continuous monitoring. Generation of list of equipment to be exported is done at "Equipment" level. With Edit Export option, you can delete equipment that you do not want to continue monitoring.

Explanation of operation and configuration of export is made in tools section.

Move measurements

You can move measurements within the tree, as long as you want to move it to a measurement that is:

- Of same type (Acceleration or Velocity or Displacement or Envelope)
- With same F Max
- With same number of lines.

To move a measurement, cursor must be positioned over measurement of desired variable and options are opened with right button. Select move measurement

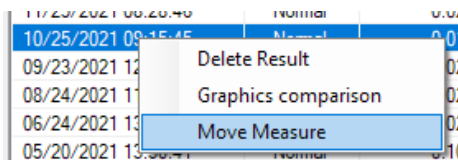

Then go to the tree and right click on measurement where you want to include data. Click on Paste measurement

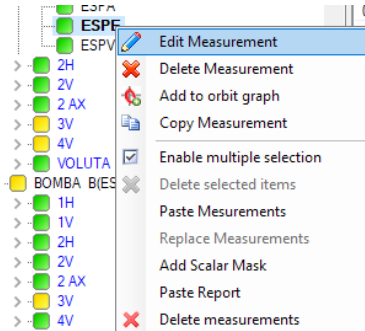

Delete Measurements

Likewise, measurements that technician considers non-useful can be eliminated. To do this we must go to "Results" tab, we position ourselves on measurement to be deleted and with right click we select "Delete result" from menu.

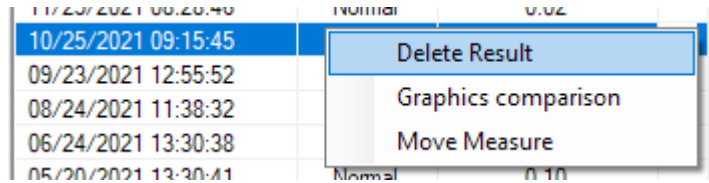

Analysis tools

In spectrum graphs and in a waveform, system has a series of icons above graph. These are analysis tools and their utility is detailed below.

Cursor Marking Main Icon



Cursors tool, grouped on an icon, contains 3 types of tools, Harmonics, Sidebands and Maximum Peaks.

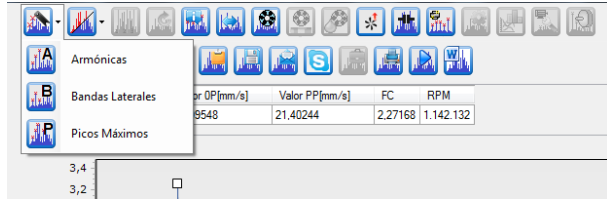

Harmonics



Once this tool is selected, we must simply click on a component of the spectrum and harmonics of this will be marked.

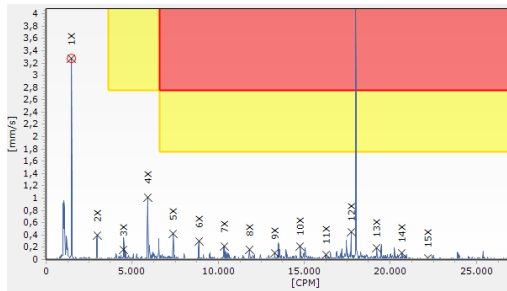

Pressing Esc key will still activate harmonic function, but the option to move location of 1X with keyboard arrows to left and right of original position will be available.

	1X	2X	3X	4X	5X
Y [mm/s]	3,25544	0,81981	0,88172	0,63966	0,08571
X [CPM]	630,00000	1.260,00000	1.897,50000	2.527,50000	3.157,50000

Side bands

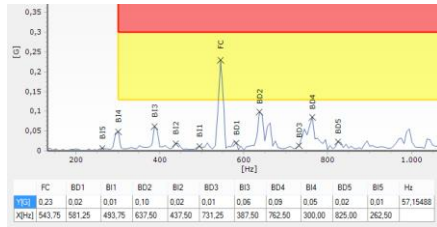

Once this tool is selected and clicking on a component, side bands will be marked on one side and the other of selected component, taking into account configured separation.

Pressing Esc key, Sidebands function will continue to be activated, but the option to move location of bands with keyboard arrows to left (zooming in) and right (further away) from original position will be available.

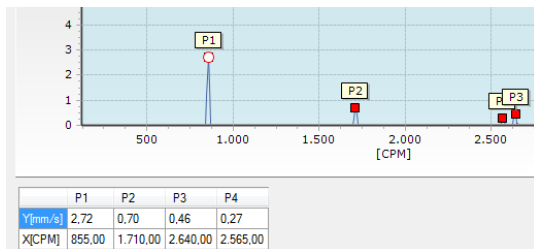

Maximum Peaks



Once activated, this tool will locate maximum peaks within spectrum.

Main icon for changing scales in spectrum



Scales tool, grouped on an ICON, contains 4 types of change tools, Hz / CPM, metric/imperial, linear and logarithmic and G/m/s².

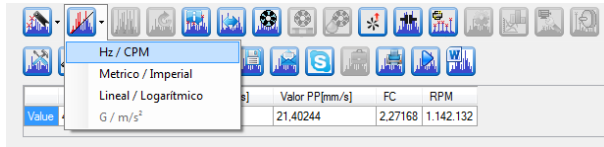

Hz/CPM - Change of units in frequencies:

This function allows you to change frequency scale of any system spectrum from HZ to CPM, however, configuration to see them by default in a certain way when opening it depends on configuration of tools, this option is only temporary.

Metric/Imperial - Change of measurement system in spectra:

By means of this ICON you can change units of amplitude axis of VELOCITY spectra of any definition, from METRIC system to IMPERIAL system.

Velocity Measurements

Metric: mm/s

Imperial: in/s

Linear / Logarithmic - Amplitude scale change in spectra:

This function allows you to change amplitude scale of any spectrum of system, being able to select it in "Linear" or "Logarithmic", since there are functions and analysis that will require the of this tool.

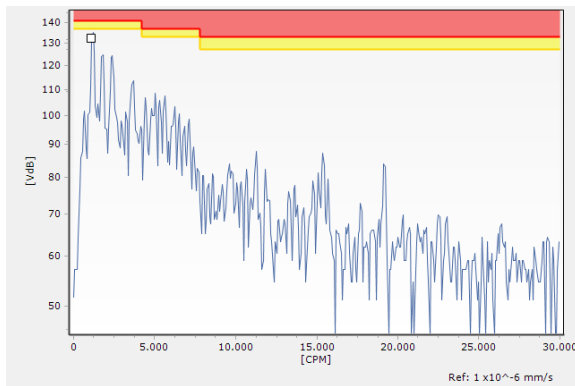
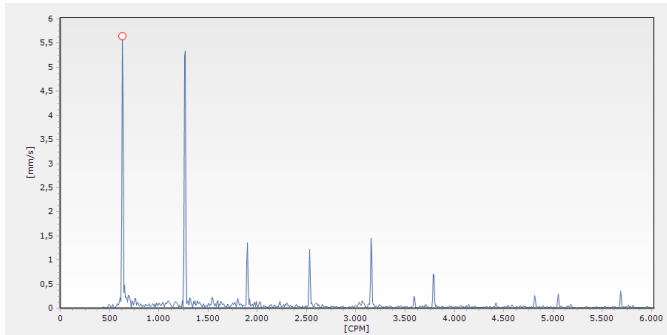

linear scale may be adequate in cases where components are all nearly the same size, but in case of machinery vibration, incipient failures in parts such as bearings produce signals with very small amplitudes.

If we want to establish a trend in the levels of these spectrum components, it is better to plot the logarithm of amplitude rather than amplitude itself. In this way we can easily display and visually interpret a dynamic range of at least 5000 to 1 or more than 100 times better than what a linear scale allows.

On a logarithmic scale, multiplication of signal level translates into an addition. This means that changing

the amount of amplification of a vibration signal will not affect shape of spectrum.

G / m/s2 Change of measurement system in spectra

By means of this ICON it is possible to change units of the amplitude axis of ACCELERATION spectra of any definition, from system G to m/s2

Configuration tools



From tools configuration you can define parameters to enhance the analysis.

All the settings of these tools are saved and each user can save their own configuration.

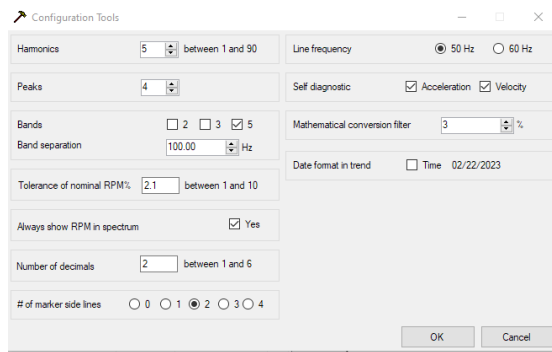

Vertical axis zoom



Function to modify ascending and descending amplitude axis of spectral graph.

Maximize spectrum



When spectrum is opened, system tries to show all series, spectral graph and alarms, if amplitude difference is great between spectral components and alarms, these components will

remain almost imperceptible and to analyze them amplitude scale must be modified with max tool.

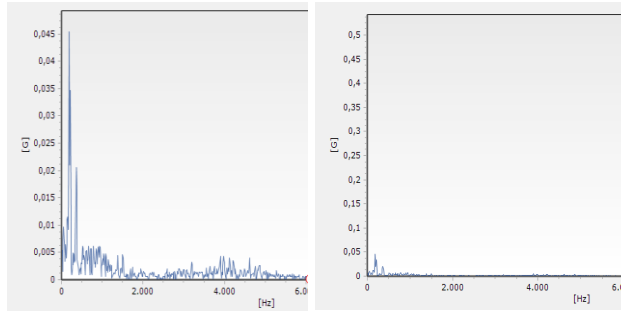

Spectrum reset



Function to reset Zoom settings and return to default setting.

Also, uncheck spectrum pointers to restart an analysis without traces of markings already made.

Calculation of actual RPM frequency



This tool allows you to calculate exact RPM of a rotor from an estimated data.

Save a spectrum



Saves a spectrum in a directory, a file, with a name determined by the user and with a configurable extension of various types.

Images, texts and data

Copy image to clipboard



By activating this function, spectral graph will be available from clipboard to be pasted into another program if necessary.

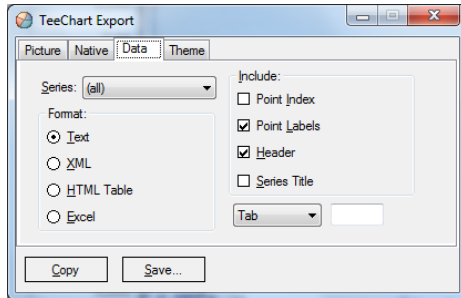
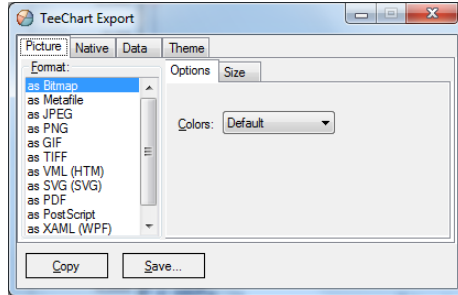

Send spectrum by e-mail



This tool opens mail program and attaches the spectrum image so that it can be sent to a recipient.

Print spectrum



Prints spectrum as seen by default printer on PC.

Export Spectrum to Microsoft Word



Generates a Word file with spectrum image and its corresponding information.

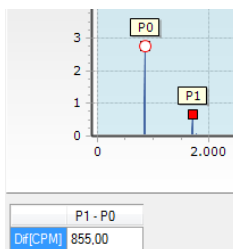
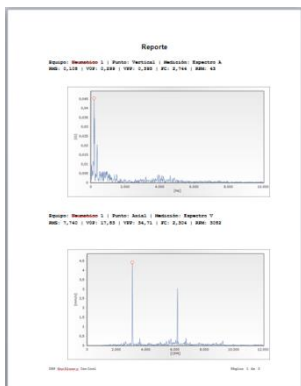

Skype



If you have SKYPE application installed, it allows you to make a video call with our technicians.

Play



With this function, you can scroll through spectra.

Spectral distance



Calculates frequency difference between two or more components, after activating the tool you must click on two components between which you want to calculate their separation.

Spectrum by order



When activating this tool, X axis is modified and scale is adjusted to orders according to speed in RPM.

Bearing failure frequencies



This tool allows you to mark characteristic frequencies of bearing failures on the spectra. To do this, you must first enter rotation RPM and manufacturer and bearing code as data.

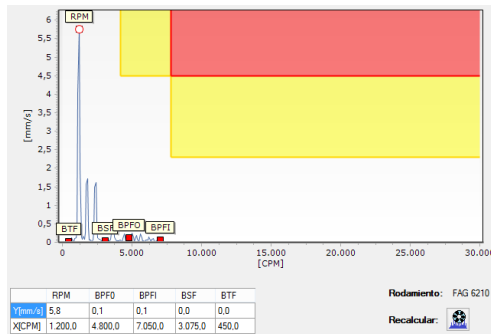

Gear and Belt Frequency



These tools calculate failure frequencies of a gearbox or belt drive with appropriate data input and display them on spectrum.

Frecuencia de Engrane

Engranes	RPM	Nº Dientes Engrane	Amplificos
Fe1	743	33	<input checked="" type="checkbox"/>
Fe2	0	0	<input type="checkbox"/>
Fe3	0	0	<input type="checkbox"/>
Fe4	0	0	<input type="checkbox"/>
Fe5	0	0	<input type="checkbox"/>

Frecuencia de Correa

Correas	RPM Polea	Dímetro de polea [mm]	Longitud de correa [mm]	Amplificos
FC1	1485	230	1850	<input checked="" type="checkbox"/>
FC2	0	0	0	<input type="checkbox"/>

Diagnostic tools in velocity and displacement.

Balancing analysis



This tool analyzes vibration level coinciding with rotation of analyzed rotor and displays a “Normal”, “Caution” or “Emergency” status based on recommended standards.

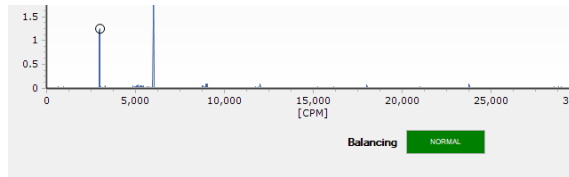

Alignment analysis



This tool analyzes vibration level coinciding with 2nd and 3rd harmonics of analyzed rotor and displays a "Normal", "Caution" or "Emergency" status based on recommended standards.

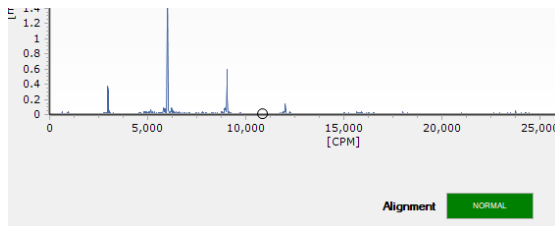

Mechanical clearance analysis



This tool analyzes vibration level coinciding with 3rd, 4th and 5th harmonics of analyzed rotor and displays a "Normal", "Caution" or "Emergency" status based on recommended standards.

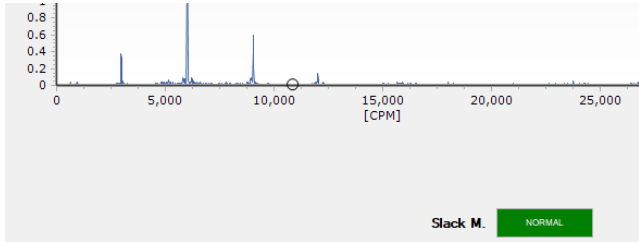

These 3 previous tools are only available when a spectrum of Velocity or Displacement is analyzed in results.

Velocity diagnostic tools.

Component identification



This tool identifies main harmonics and places texts of the possible causes of each one.

Diagnostic tools in acceleration

Bearing analysis



This tool analyzes condition of bearing for selected point and displays an “Acceptable”, “Caution” or “Emergency” status based on recommended standards and rotor RPM.

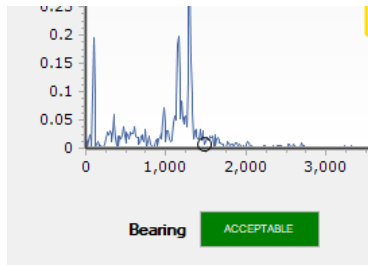

Lubrication analysis



This tool analyzes condition of lubricating film of bearing corresponding to selected point and displays an “Acceptable”, “Caution” or “Emergency” status based on recommended standards

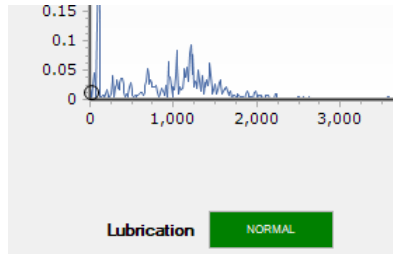

These two tools will only be available when deploying a spectrum of Acceleration

Math conversion



This tool allows you to change the variable of a spectrum, that is to say that a spectrum measured in acceleration can be seen in velocity or displacement

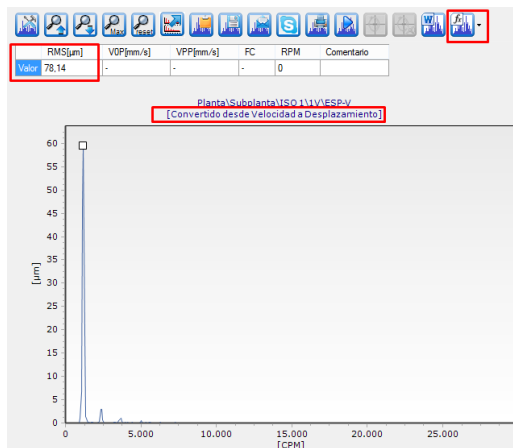

and vice versa, also showing the RMS value of calculated variable.

Maximize graph



This tool allows you to expand the graph of both waveform and spectrum, in this way, by double clicking on Results tab and applying this tool, you will have a graph that covers entire screen, allowing a much more comfortable view of the graph to be analyzed.

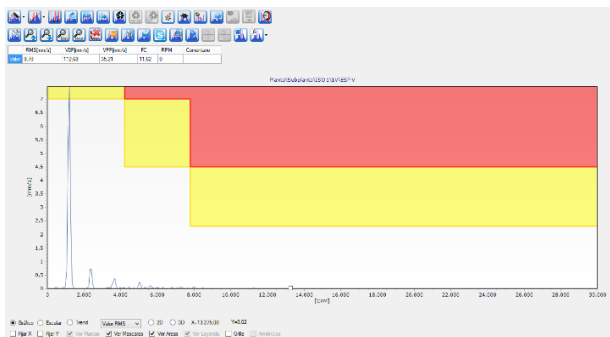

ISO – IEC norm



This tool shows on a trend graph status of measured values according to ISO 10816 IEC 60034 standards, graphically representing by colors values that reach acceptable levels or not according to these standards.

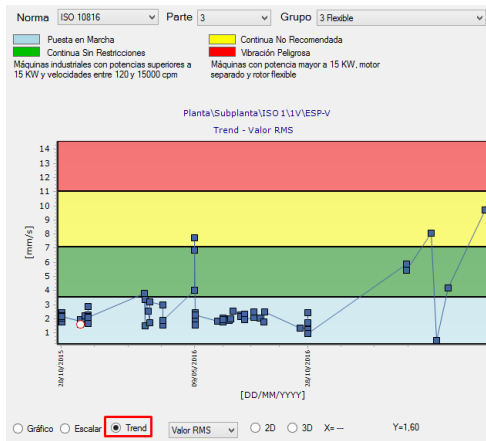

Alarm level modification



This tool allows you to modify alarm levels, both for precaution and for emergency, in individual percentages for each.

New alarm level must be recorded with a new name and will be associated with the modified measurement.

Keep in mind that statuses prior to modification will NOT be changed.

Electrical analysis



This tool is prepared to automatically determine status of a rotor of an asynchronous three-phase motor.

It is only available if a current spectrum is measured with an ammeter clamp connected to an AC input, network frequency data must be entered, synchronous speed and motor rpm

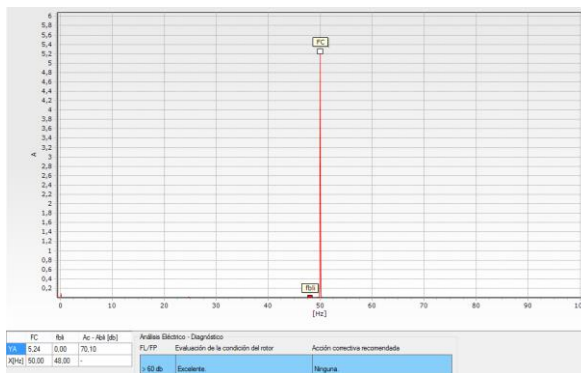

Waveform analysis tools

Orbital chart



Allows you to visualize waveform measurement in orbital form

Analisis Eléctrico

Frecuencia de Línea: 50 Hz 60 Hz

Frecuencia Real de Alimentación: Hz

RPM Nominal:

Nº de Pólos: 3000 / 50 (2) 1500 / 25 (4) 1000 / 15.47 (6) 750 / 12.5 (8) 600 / 10 (10) 500 / 8.33 (12)

Reports

System allows generation of configurable reports.

Before proceeding to create a report, you must first define which equipment's will be part of that report, this step is done simply by right-clicking on equipment's that you want to include in the report (one at a time) and selecting "Include Equipment in Report"

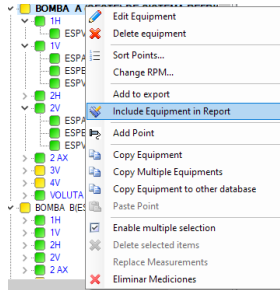

You can also choose to add all the equipment to report by right-clicking on Subplant and choosing that option from drop-down menu.

Then in main menu go to Tools option and then Create Report, a window will be displayed that will allow you to configure a PDF spreadsheet where you can add a company name, logo, define a directory to save these spreadsheets and select measurement

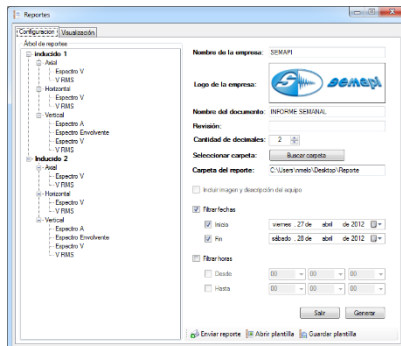

interval of selected equipment's to be included in report.

If these reports are to be made routinely, it is convenient to save the template so as not to have to generate it again.

01

Fecha	Hora	Param.	Medición	Unid.
14.03.2012	11:02:00	3	Ph.C.	g.10
14.03.2012	11:03:00	3	Ph.C.	g.1

01-IMP

Fecha	Hora	Param.	Medición	Unid.
14.03.2012	11:02:00	3	Ph.C.	g.10
14.03.2012	11:03:00	3	Ph.C.	g.10
14.03.2012	11:04:00	3	Ph.C.	g.10
14.03.2012	11:05:00	3	Ph.C.	g.10
14.03.2012	11:06:00	3	Ph.C.	g.10
14.03.2012	11:07:00	3	Ph.C.	g.10
14.03.2012	11:08:00	3	Ph.C.	g.10
14.03.2012	11:09:00	3	Ph.C.	g.10
14.03.2012	11:10:00	3	Ph.C.	g.10
14.03.2012	11:11:00	3	Ph.C.	g.10
14.03.2012	11:12:00	3	Ph.C.	g.10
14.03.2012	11:13:00	3	Ph.C.	g.10
14.03.2012	11:14:00	3	Ph.C.	g.10
14.03.2012	11:15:00	3	Ph.C.	g.10
14.03.2012	11:16:00	3	Ph.C.	g.10
14.03.2012	11:17:00	3	Ph.C.	g.10
14.03.2012	11:18:00	3	Ph.C.	g.10
14.03.2012	11:19:00	3	Ph.C.	g.10
14.03.2012	11:20:00	3	Ph.C.	g.10
14.03.2012	11:21:00	3	Ph.C.	g.10
14.03.2012	11:22:00	3	Ph.C.	g.10
14.03.2012	11:23:00	3	Ph.C.	g.10
14.03.2012	11:24:00	3	Ph.C.	g.10
14.03.2012	11:25:00	3	Ph.C.	g.10
14.03.2012	11:26:00	3	Ph.C.	g.10
14.03.2012	11:27:00	3	Ph.C.	g.10
14.03.2012	11:28:00	3	Ph.C.	g.10
14.03.2012	11:29:00	3	Ph.C.	g.10
14.03.2012	11:30:00	3	Ph.C.	g.10

ISO 1

Fecha	Hora	Param.	Medición	Unid.
14.03.2012	11:02:00	3F	Ph.C.	g.10
14.03.2012	11:03:00	3F	Ph.C.	g.10
14.03.2012	11:04:00	3F	Ph.C.	g.10
14.03.2012	11:05:00	3F	Ph.C.	g.10
14.03.2012	11:06:00	3F	Ph.C.	g.10
14.03.2012	11:07:00	3F	Ph.C.	g.10
14.03.2012	11:08:00	3F	Ph.C.	g.10
14.03.2012	11:09:00	3F	Ph.C.	g.10
14.03.2012	11:10:00	3F	Ph.C.	g.10
14.03.2012	11:11:00	3F	Ph.C.	g.10
14.03.2012	11:12:00	3F	Ph.C.	g.10
14.03.2012	11:13:00	3F	Ph.C.	g.10
14.03.2012	11:14:00	3F	Ph.C.	g.10
14.03.2012	11:15:00	3F	Ph.C.	g.10
14.03.2012	11:16:00	3F	Ph.C.	g.10
14.03.2012	11:17:00	3F	Ph.C.	g.10
14.03.2012	11:18:00	3F	Ph.C.	g.10
14.03.2012	11:19:00	3F	Ph.C.	g.10
14.03.2012	11:20:00	3F	Ph.C.	g.10
14.03.2012	11:21:00	3F	Ph.C.	g.10
14.03.2012	11:22:00	3F	Ph.C.	g.10
14.03.2012	11:23:00	3F	Ph.C.	g.10
14.03.2012	11:24:00	3F	Ph.C.	g.10
14.03.2012	11:25:00	3F	Ph.C.	g.10
14.03.2012	11:26:00	3F	Ph.C.	g.10
14.03.2012	11:27:00	3F	Ph.C.	g.10
14.03.2012	11:28:00	3F	Ph.C.	g.10
14.03.2012	11:29:00	3F	Ph.C.	g.10
14.03.2012	11:30:00	3F	Ph.C.	g.10

Route reports

A report can be generated from a custom route, in Routes tab, by selecting any route on right side of screen, a list of dates for carrying out routes is available, double-clicking on one of them opens a dialog box that allows you to create the report where measured equipment will be displayed with its status, its values and if it had an increase compared to previous measurement.

Equipos Portátiles		Reutas	Reportes
1	5 Fx Tr A Flex		
Filtros			
ISO 1			
ISO 2			
Promotor motor			
Promotor sala			
Rutas W FO			
Rutas 1			

Reportes de Rutas			
No	Fecha	Cant. Reportes	Cant. Equipos Medicos
1	27-03-2017	2	2
2	03-05-2017 (1)	2	2
3	11-05-2017 (1)	2	2
4	26-05-2017 (1)	2	2
5	07-07-2017 (1)	2	2
6	24-07-2017 (4)	2	2

Parámetros de Exportación de Reportes

Analista:

Ruta/Planta:

Semaps:

Título Pie de Página:

Descripción Pie de Página:

Detalle Pie de Página:

Logo: 

Seleccionar...

Abrir reporte al terminar.

Tipo de Reporte (Estado de Medición)

Todos

Normal

Excesivos

SEMAPI		REPORTE DE RUTA					
PLANTARUTA: Semapi							
ANALISTA: Nestor						FECHA: 26/07/2017	
Equipo/Punto	Variable	Valor	Tendencia	Estado	Fecha	Comentario	
ISO 1							
1V	Aceleración	0,08 G	15,93 %	Normal	24/07/2017		
1V	Velocidad	9,7 mm/s	0 %	Precaución	24/07/2017		
2V	Aceleración	0,11 G	37,61 %	Normal	24/07/2017		
2V	Velocidad	9,04 mm/s	165,41 %	Precaución	24/07/2017		
3V	Aceleración	0,11 G	46,46 %	Normal	24/07/2017		
3V	Velocidad	4,61 mm/s	38,23 %	Normal	24/07/2017		
4V	Aceleración	0,12 G	72,68 %	Normal	24/07/2017		
4V	Velocidad	4,82 mm/s	55,97 %	Normal	24/07/2017		
ISO 2							
1V	Aceleración	0,1 G	47,04 %	Normal	24/07/2017		
1V	Velocidad	4,78 mm/s	47,32 %	Normal	24/07/2017		
2V	Aceleración	0,13 G	88,83 %	Normal	24/07/2017		
2V	Velocidad	4,88 mm/s	35,56 %	Normal	24/07/2017		
3V	Aceleración	0,1 G	31,99 %	Normal	24/07/2017		
3V	Velocidad	5,14 mm/s	56,02 %	Normal	24/07/2017		
4V	Aceleración	0,12 G	45,75 %	Normal	24/07/2017		
4V	Aceleración	0,15 G	98,72 %	Sin Mascara	24/07/2017		
4V	Velocidad	4,64 mm/s	48,89 %	Normal	24/07/2017		

SEMAPI provides technical information on the Internet to help you use its products at: <http://www.dsplogger.com>, you can find technical manuals, a database with frequently asked questions and application notes.

You can also find DSP Logger Expert firmware instructional videos at <https://www.youtube.com/user/semapicorp>